

Operator's manual



N 200-4 Li Recharger CLi

english



Contents

1.	Safety	4
1.1	General safety information.....	4
1.2	Specific safety information.....	5
2.	Description	6
2.1	Intended use	7
2.2	Technical data	8
3.	Setting work	9
3.1	Loading the rechargeable battery.....	9
3.2	Changing the battery	12
4.	Operation	13
4.1	Working with the N 200-4 Li.....	14
4.2	Changing the cutting direction	15
4.3	Making interior cutouts.....	16
4.4	Nibbling with templates.....	16
5.	Maintenance	17
5.1	Replacing the tool	18
	Disassembling the punch	19
	Installing the punch.....	19
	Replacing the die	19
6.	Original accessories and wearing parts.....	20

Guarantee

Replacement parts list

Addresses

1. Safety

1.1 General safety information

- Read the operator's manual and the safety information (Order No. 125699) in their entirety before starting up the machine. Closely follow the instructions given.
- Adhere to the safety regulations in accordance with DIN VDE, CEE, AFNOR and to the specific regulations of the country of operation.



Danger

Risk of fatal injury from electric shock!

- Do not touch the electrical contacts on the recharger or on the rechargeable battery.
-



Warning

Risk of injury from the rechargeable battery

- Always remove the rechargeable battery from the machine prior to maintenance work.
 - Check the machine and the rechargeable battery for damage each time before use.
 - Keep the machine dry and do not operate it in damp rooms.
 - Charge the exchangeable battery of the Li-Ion Energy 28 V system only with the recharger of the Li-Ion Energy 28 V system.
 - Do not attempt to open the exchangeable batteries or the recharger.
 - Do not dispose of the exchangeable batteries in fires or household waste.
-



Warning

Risk of injury due to improper handling.

- Wear safety glasses, hearing protection, protective gloves and work shoes when working at the machine.
-



Caution

Damage to property due to improper handling

The machine will be damaged or destroyed.

- Have servicing and inspections of hand-held electric tools and recharger carried out by a qualified specialist. Only use original accessories provided by TRUMPF.
-

1.2 Specific safety information



Warning

Risk of injury due to improper handling.

- Make sure the machine is always in a stable position when operating it.
 - Never touch the tool while the machine is running.
 - Always operate the machine away from your body.
 - Do not operate the machine above your head.
-



Warning

Risk of injury to hands.

- Do not reach into the processing line with your hands.
 - Use both hands to hold the machine.
-



Warning

Risk of injury from high-temperature chips!

High-temperature chips are produced at high speeds.

- Use a chip bag.
-



Warning

Health risk from breathing cutting oil!

- Ensure adequate ventilation when working with cutting oil.
 - Do not inhale vapors that occur.
-

2. Description



Nibbler N 200-4 Li with recharger

Fig. 53343

2.1 Intended use

**Warning**

Can cause injury or damage to health!

- Only use the machine for work and materials described in "Intended use".
 - Do not process any materials containing asbestos.
-

The TRUMPF Nibbler N 200-4 Li is an electrical hand-held device used for the following applications:

- Slitting plate-shaped workpieces made of a punchable material such as steel, aluminum, non-ferrous heavy metals, and plastic.
- Nibbling straight or curved exterior and interior cutouts.
- Slitting tubes as well as machining sectional sheets.
- Nibbling along scribed lines or templates.

Note

The nibbling process produces cutting edges free of deformations.

Note

Because of the hollow round punch, the nibbler can be rotated at any position such that processing can continue in any direction.

The CLi recharger charges exchangeable batteries of the Li-Ion Energy 28 V system.

2.2 Technical data

	Other countries	USA
	Values	Values
Voltage	28 V	28 V
Steel 400 N/mm²	2.0 mm	0.08 in
Steel 600 N/mm²	1.5 mm	0.06 in
Steel 800 N/mm²	1.0 mm	0.039 in
Aluminum 250 N/mm²	2.5 mm	0.1 in
Working speed	1.3 m/min	4.3 ft/min
Idle stroke rate	1600/min	1600/min
Weight with rechargeable battery	3.4 kg	7.6 lbs
Weight without rechargeable battery	2.3 kg	5.1 lbs
Start hole diameter	16 mm	0.630 in
Smallest radius with curved cuts	4 mm	0.16 in

Technical data N 200-4 Li

Tab. 1

Voltage	18-28 V
Loading time at 28 V	approximately 1 h
Weight without power cord	700 g

Technical data CLi recharger

Tab. 2

Vibration	Specifications in accordance with EN 12096 Measured values in accordance with EN ISO 8662-10
Vibration value at the handle a	3.5 m/s ²
Uncertainty K	1.5 m/s ²

Tab. 3

Measured values were measured while machining sheet steel 400 N/mm with max. material thickness.

Noise emissions	Specifications in accordance with EN ISO 4871 Measured values in accordance with EN ISO 15744
A-rated sound level L _{WA}	106 dB
A-rated acoustic power level at the work place L _{PA}	92 dB

Tab. 4

The noise emission values given are the sum of the measured values and the corresponding uncertainties. They represent an upper value limit which can emerge during measurements.

3. Setting work

3.1 Loading the rechargeable battery



Risk of fatal injury from electric shock!

Line voltage is present at the battery terminals.

- Do not touch the electrical contacts (battery terminals) on the recharger.

The rechargeable battery is partially charged (50%) at the time the rechargeable battery electric tool is delivered.

Checking loading status

Prerequisites

- The electric tool has been switched off for at least 1 minute.

- Press the key on the rechargeable battery.

The LEDs on the rechargeable battery show the charging status.

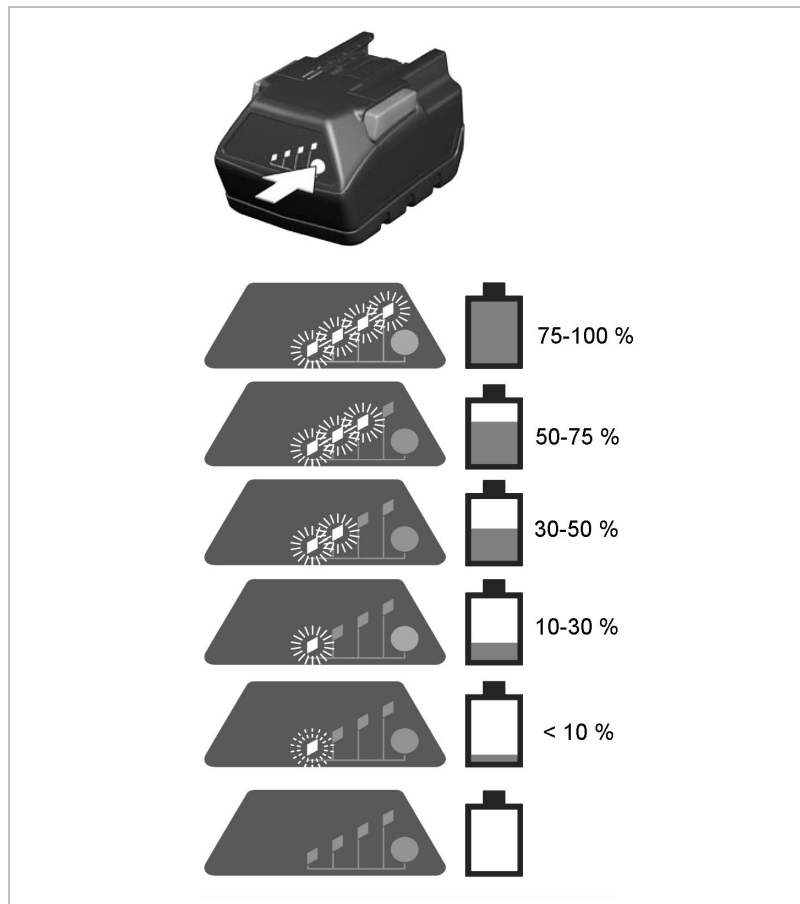

Check charging status on the rechargeable battery

Fig. 53299

Loading the rechargeable battery

Before using the cordless electric tool, a new exchangeable battery or one that has not been used for a long time needs to be charged.

Note

The full capacity is reached after 2-10 charging cycles.



Fig. 53300

- Insert the exchangeable battery into the insertion well on the recharger.

The loading time is between 1 min and 60 min, depending on how far the rechargeable battery had been discharged beforehand. The rechargeable battery is completely charged after 60 min.

The maximum charging current flows when the temperature of the rechargeable battery is between 0° and 66°C. If a rechargeable battery is inserted into the recharger that is too cold or too warm (red LED flashes), then the charging process will begin automatically as soon as the rechargeable battery has reached the correct charging temperature (-10°C to +66°C).



Status display on the recharger



1 Status display

Recharger CLi

Fig. 53306

Display	Function
Red continuous	Loading
Green continuous	Rechargeable battery is full
Red, flashing	Rechargeable battery too warm/cold
Flashing red and green	Error in the rechargeable battery

Tab. 5

3.2 Changing the battery

Removing the exchangeable battery

- Press the locking mechanism (1) together and pull the exchangeable battery out and upwards.

Inserting the exchangeable battery

- Slide the exchangeable battery into the machine holder from above until the battery locks into place.

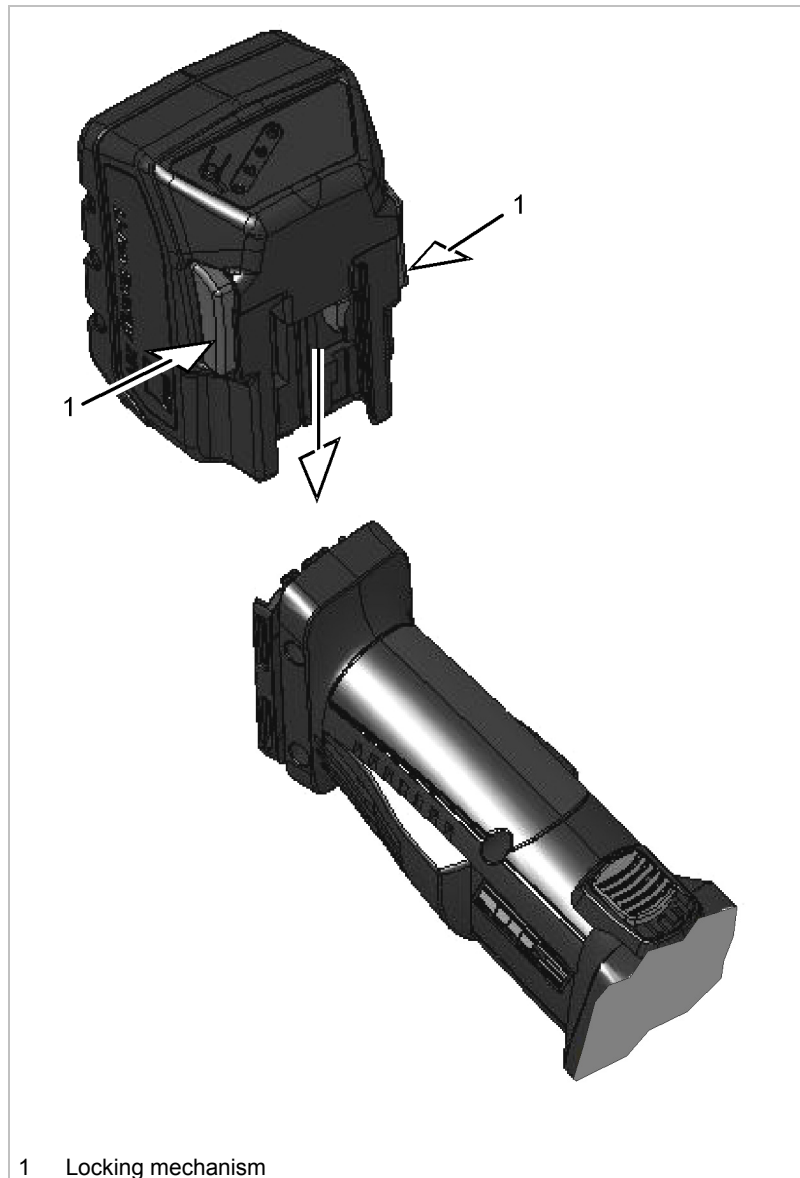

Fig. 53321

4. Operation



Warning

Risk of injury due to improper handling.

- Make sure the machine is always in a stable position when operating it.
- Wear safety glasses, hearing protection, protective gloves and work shoes when working at the machine.
- Never touch the tool while the machine is running.
- Always operate the machine away from your body.
- Do not operate the machine above your head.



Warning

Health risk from breathing cutting oil!

- Ensure adequate ventilation when working with cutting oil.
- Do not inhale vapors that occur.



Caution

Damage to property caused by blunt tools!

Machine overload.

- Check the cutting edge of the punch hourly for wear: A sharp punch provides good cutting performance and is easier on the machine.
- Replace punches promptly.

Motor overload protection

The motor shuts off with excess load.

- Allow the machine to run in idle until it has cooled down.

The machine can be operated again normally after it has cooled down.

Note

Coat the cutting edges with oil before machining steel and aluminum or aluminum alloys. In this way:

- The cutting result is improved.
- The service life of the punch is increased.

Material	Oil
Steel	Punching and nibbling oil (0.5 l, order no. 103387)
Aluminum	Akamin oil (1 l, order no. 125874)

Tab. 6

4.1 Working with the N 200-4 Li

Before using the cordless electric tool, a new exchangeable battery or one that has not been used for a long time needs to be activated.

Activating rechargeable battery

- Place rechargeable battery briefly on the recharger or charge it completely.

The LED on the rechargeable battery shows the charging status.

Note

The performance capacity of the rechargeable battery is available to only a limited extent at temperatures below -10°C .

Discharging the rechargeable battery

The rechargeable battery shuts off automatically when it is completely discharged. The rechargeable battery emits brief electricity pulses when the electrical tool is switched on.

Switching on the N 200-4 Li

- Slide the On/Off switch forwards.

Note

If the electric tool does not work after being switched on, stick the rechargeable battery on the recharger and check the charging status.



Rechargeable battery Li-Ion Energy 28 V

Fig. 53294

Working with the N 200-4 Li

1. Do not move the machine towards the workpiece until full speed has been reached.
2. Machine the material.
 - Machine the desired cutting line
3. In the event that the cutting track ends in the sheet, pull the still-running machine a few millimeters back towards where the cutting track has already been cut open.

4. Switch the machine off.

Switching off the N 200-4 Li ➤ Slide the On/Off switch to the rear.

4.2 Changing the cutting direction

The direction of the cut can be rotated to the right or the left in 5° increments as needed.

- For right-handed/left-handed operation.
- Machining sectional sheets.

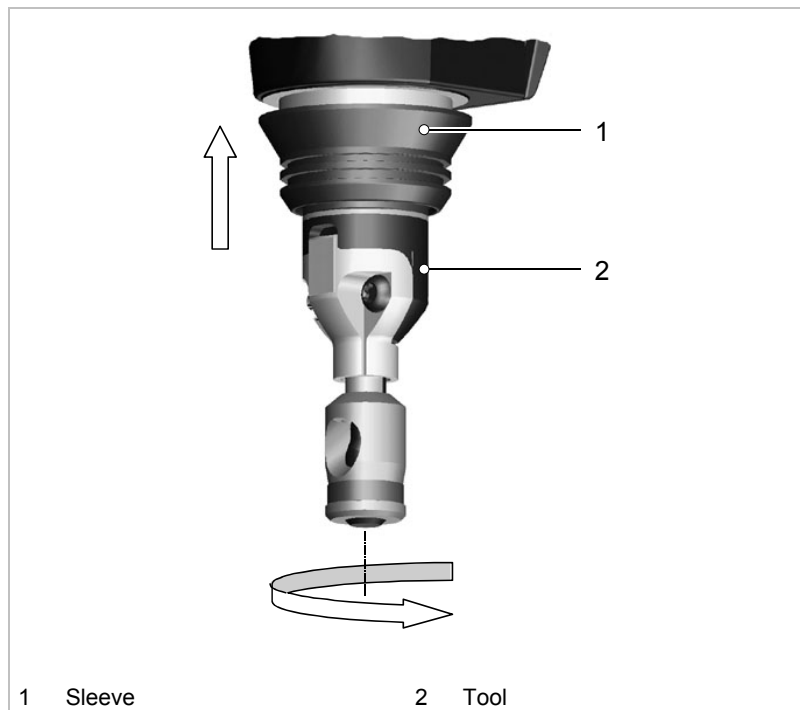

Fig. 25666

1. Push the sleeve (1) up until it stops.
2. Turn the tool (2) to the desired direction.
3. Release the sleeve (1) and turn the tool (2) slightly such that it locks into the next index position.

4.3 Making interior cutouts

- Make a start hole at least 16 mm in diameter.

4.4 Nibbling with templates

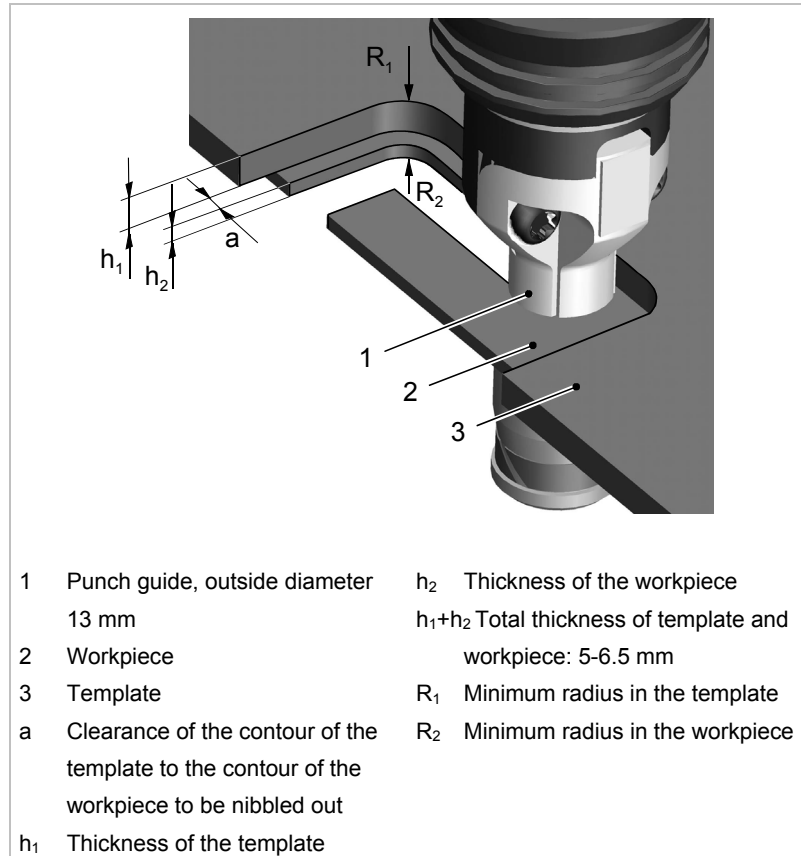

Fig. 25828

5. Maintenance



Warning

Risk of injury from the rechargeable battery

- Remove rechargeable battery when changing tools and before performing any maintenance work on the machine.



Warning

Risk of injury due to repair work not being carried out properly!

Machine does not work properly.

- Repair work may only be carried out by a qualified technician.



Caution

Damage to property caused by blunt tools!

Machine overload.

- Check the cutting edge of the punch hourly for wear: A sharp punch provides good cutting performance and is easier on the machine.
- Replace punches promptly.

Maintenance point	Procedure and interval	Recommended lubricant	Lubricant order no.
Punch guide	With each tool change	Lubricating grease "G1"	121486
Gearbox and gear head	After 300 operating hours, arrange for a qualified technician to relubricate or to replace the lubricating grease.	Lubricating grease "G1"	139440
Punch	Replace as needed	-	-
Die	Replace as needed	-	-
Rechargeable battery	Replace as needed	-	-

Maintenance positions and maintenance intervals

Tab. 7

5.1 Replacing the tool

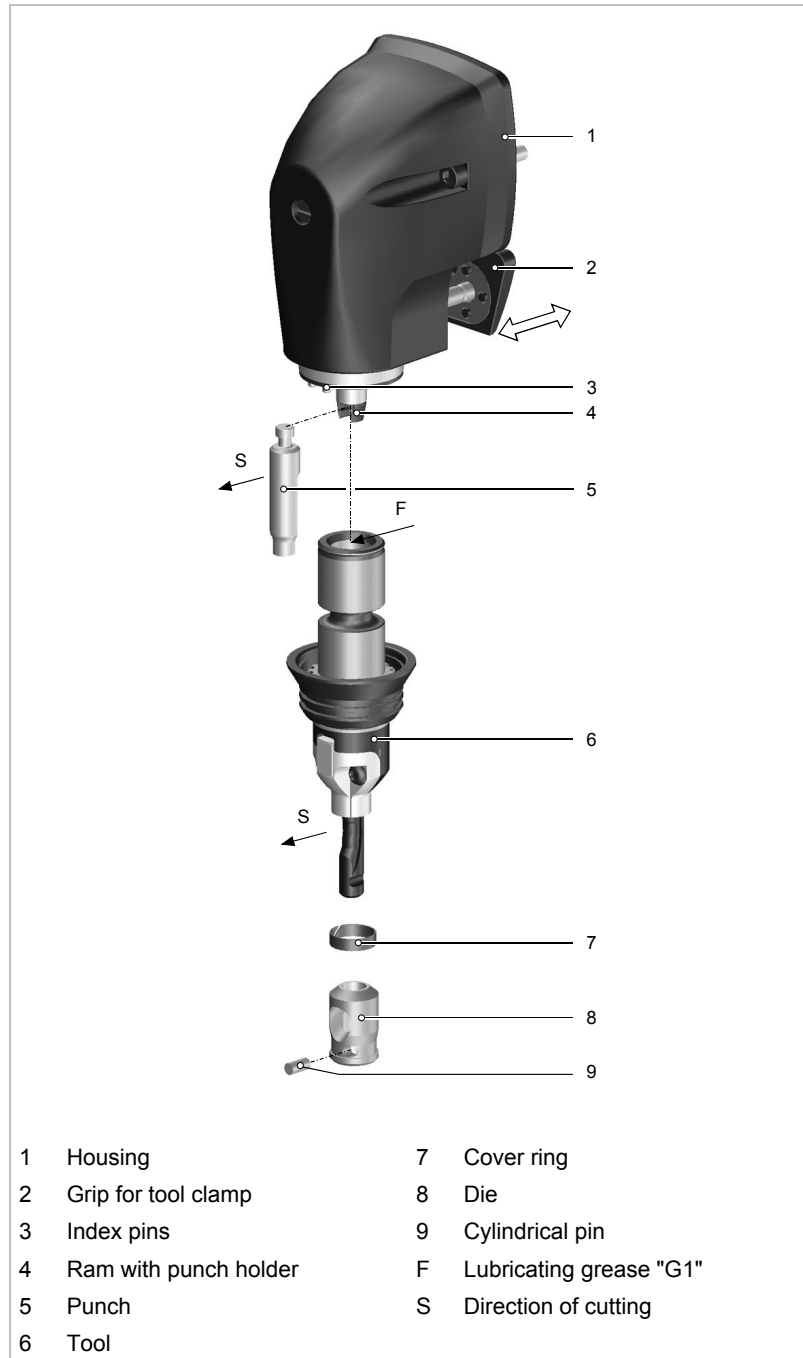

Fig. 25655

- If the punch or die becomes blunt, change the tool.

Disassembling the punch

1. Pull handle (2) back.
2. Pull tool (6) out of the housing (1).
3. Remove punch (5).

Installing the punch

1. Lightly lubricate the punch (5) and the boring in the tool (6) with lubricating grease "G1".
2. Hang the punch in the groove of the punch holder.
3. Align the cutting direction towards the front.
4. Insert tool (6) into the housing (1) with cutting direction facing towards the front.
5. Slide handle (2) back; the tool (6) is kept in the housing.

Replacing the die

1. Push cover ring (7) upward out of slot.
2. Push out cylindrical pin (9) using a drift punch.
3. Pull off die (8) from the carrier pin and replace it with a new die.
4. Set die on the carrier pin.
5. Mount cylindrical pin.
6. Slide the cover ring in the groove downwards.

6. Original accessories and wearing parts

N 200-4 Li	Supplied original accessories	Wearing parts	Options	Order number
Punch	+	+		0944506
Die	+	+		0994799
Lubricating grease "G1"	+			0344969
Case	+			1470139
Operator's manual	+			1467654
Safety information (red document)	+			0125699
Chip bag			+	0088622
Punching and nibbling oil for steel (0.5 litre)			+	0103387
Torx wrench Tx20			+	0359907
Tool PN 200-2			+	0961964
Tool PN 161-2			+	0961966
Rechargeable battery 28 V	+			1464697
Recharger CLi 220-240 V	+			1464702
Recharger CLi 120 V	+			1464703

Tab. 8

Ordering wearing parts To ensure the correct and fast delivery of original parts and wearing parts:

1. Specify the order number.
2. Enter further order data:
 - Voltage data.
 - Quantity.
 - Machine type.
3. Provide complete shipping information:
 - Correct address.
 - Desired delivery type (e.g. air mail, courier, express mail, ordinary freight, parcel post).
4. Send the order to the TRUMPF representative office. For TRUMPF service addresses, see www.trumpf-powertools.com.