

Operator's manual



TruTool F 305 (1A1)

TRUMPF GmbH + Co. KG, Technische Redaktion
Johann-Maus-Straße 2, D-71254 Ditzingen
Fon: +49 7156 303 - 0, Fax: +49 7156 303 - 930540
Internet: <http://www.trumpf.com>
E-Mail: docu.tw@de.trumpf.com



Table of contents

1	Safety	2
1.1	General safety information	2
1.2	Specific safety information for seam lockers	2
2	Description	4
2.1	Intended use	4
2.2	Technical data	6
2.3	Icons	6
2.4	Noise and vibration information	7
3	Folding	8
4	Setting work	10
4.1	Adjusting the tool	10
5	Operation	11
5.1	Work with TruTool F 305	11
	Switching on	11
	The channel is open	11
	There is a flange at the start of the channel.	13
	Switching off	14
6	Maintenance	15
6.1	Tighten the screws to a torque	15
6.2	Replacing carbon brushes	16
7	Accessories and consumables	17
7.1	Ordering consumables	17
8	Appendix: Declaration of conformity, guarantee, replacement parts lists	18

1. Safety

1.1 General safety information

 **WARNING**



- Read all the safety information and instructions including those in the brochure also supplied.
- Failure to comply with the safety information and instructions can cause electric shock, burns and/or serious injury.
- Retain all the safety information and instructions for future use.

 **DANGER**

Electrical voltage! Risk of fatal injury due to electric shock!

- Remove the plug from the plug socket before undertaking any maintenance work on the machine.
- Check the plug, cable and machine for damage each time before using the machine.
- Keep the machine dry and do not operate it in damp rooms.
- Connect the fault current (FI) circuit breaker with a maximum breaking current of 30 mA when using the electric tool outside.
- Only use original TRUMPF accessories.

 **WARNING**

Damage to the machine due to improper handling.

- Wear safety glasses, hearing protection, breathing protection, protective gloves and working shoes when working.
- Connect the plug only when the machine is switched off. Pull the power plug after use.
- Do not carry the machine by the cable.
- Have maintenance carried out by specialists.

1.2 Specific safety information for seam lockers

 **DANGER**

Electrical voltage! Risk of fatal injury due to electric shock!

- Always keep the power cable behind the device and do not pull it over sharp edges.
- Do not perform any work that may cause the machine to come into contact with hidden power lines or its own cable. Contact with a live conductor can cause metallic machine parts to become live and can lead to an electric shock.

 **WARNING****Risk of injury to hands.**

- Do not reach into the processing line with your hands.
- Use both hands to hold the machine.

2. Description

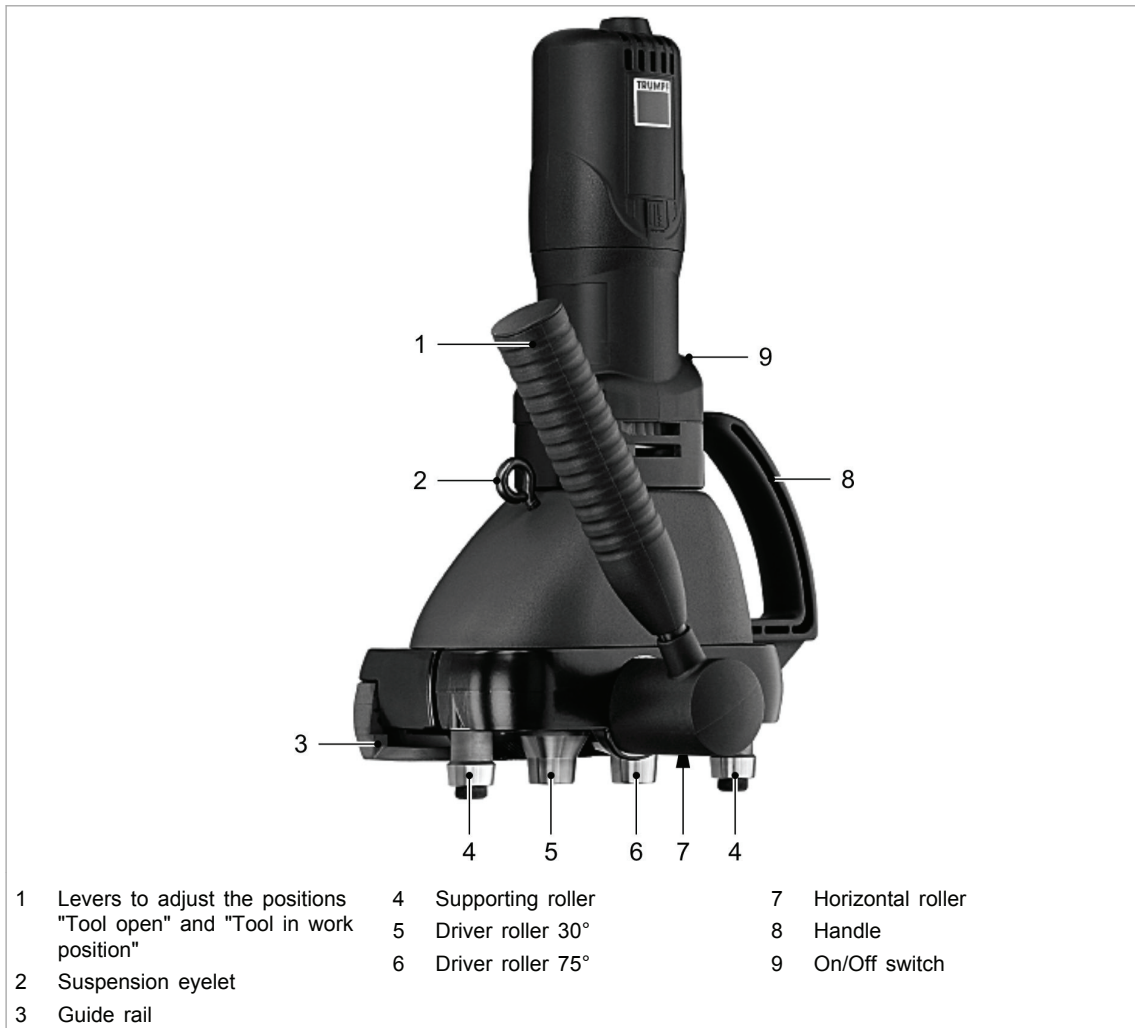

Fig. 46684

2.1 Intended use

⚠ WARNING

Damage to the machine due to improper handling.

- Only use the machine for work and materials as described under "Intended use."





The TRUMPF seam locker TruTool F 305 is an electrically powered hand-held device designed for the following applications:

- The closing of Pittsburgh lock seams on correspondingly pre-machined workpieces such as ventilation channels, housings, containers etc.
- The machining of all lock seam heights.

Notes

- Closing the seam on straight contours.
- The machine will automatically adapt to the thickness of the current sheet.

2.2 Technical data



	Other countries			USA
	Values			
Voltage	230 V	120 V	110 V	120 V
Frequency	50/60 Hz	50/60 Hz	50 Hz	50/60 Hz
Material strength 400 N/mm ²	0.45 - 0.75 mm	0.45 - 0.75 mm	0.45 - 0.75 mm	0.018-0.029 in 26–22 gauge
Working speed	4 - 7 m/min			13 - 23 ft/min
Nominal power consumption	500 W	500 W	500 W	500 W
Speed when idling n ₀	160/min			
Weight	5.2 kg			11.5 lbs
Safety class	II / 	II / 	II / 	II / 

Tab. 1

2.3 Icons

Note

The following symbols are important for reading and understanding the operator's manual. The correct interpretation of the symbols will help you operate the machine better and safer.

Icon	Name	Meaning
	Read operator's manual	Read the operator's manual and safety information in their entirety before starting up the machine. Closely follow the instructions given.
	Safety class II	Indicates a doubly insulated tool.
	Alternating current	Type or property of current
V	Volt	Voltage
A	Ampere	Current, current input
Hz	Hertz	Frequency (oscillations per second)
W	Watt	Power, power input
mm	Millimeters	Dimensions e.g.: material thickness, chamfer length
in	Inch	Dimensions e.g.: material thickness, chamfer length
n ₀	Idle speed	Revolution speed without load
.../min	Revolutions/strokes per minute	Revolution speed, stroke rate per minute

Tab. 2

2.4 Noise and vibration information

WARNING

Noise emission value may be exceeded.

- Wear hearing protection.

WARNING

The vibration emission value can be exceeded!

- Select the right tools and exchange them in time in the event of wear.
- Have maintenance carried out by trained specialized technicians.
- Define additional safety measures for protecting the operator from the effect of vibrations (e. g. keep hands warm, organization of working procedures, machining at normal feed force).
- Depending on the operating conditions and state of the electric tool, the actual load might be higher or lower than the specified measured value.

Notes

- The specified vibration emission value was measured in accordance with a standardized testing procedure and can be used to compare one electric tool with another.
- The specified vibration emission value can also be applied for a provisional estimate of the vibration load.
- Times during which either the machine is switched off or running but not actually in use can considerably reduce the vibration load during the entire working period.
- Times during which the machine works independently and self-propelled do not have to be calculated.

Designation of measured value	Unit	Value according to EN 60745
Vibration emission value a_h (vector sum of three directions)	m/s ²	≤2.5
Uncertainty K for vibration emission value	m/s ²	
A-class acoustic pressure level L_{PA} typically	dB (A)	81
A-class acoustic power level L_{WA} typically	dB (A)	85

Tab. 3

3. Folding

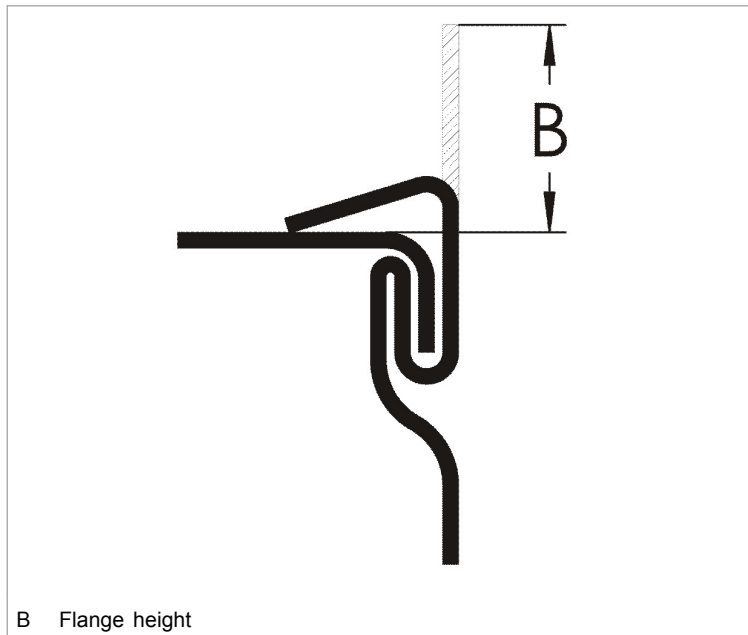

Fig. 47283

Lock seam geometry "Pittsburgh lock seam"

Sheet thickness range mm	B mm
0.45 - 0.75	5 - 10

Tab. 4

Sheet thickness range		B
in	Gauge	in
0.02 - 0.03	26 - 22	0.19 - 0.39

Tab. 5

Note

The seam quality essentially depends upon the flange height B. If B is too small, the seam cannot be properly closed. If the Pittsburgh lock seam machine is set to a sheet thickness of 1.25 mm, then the correct flange height B will automatically result for all thin sheets.

Roller arrangement

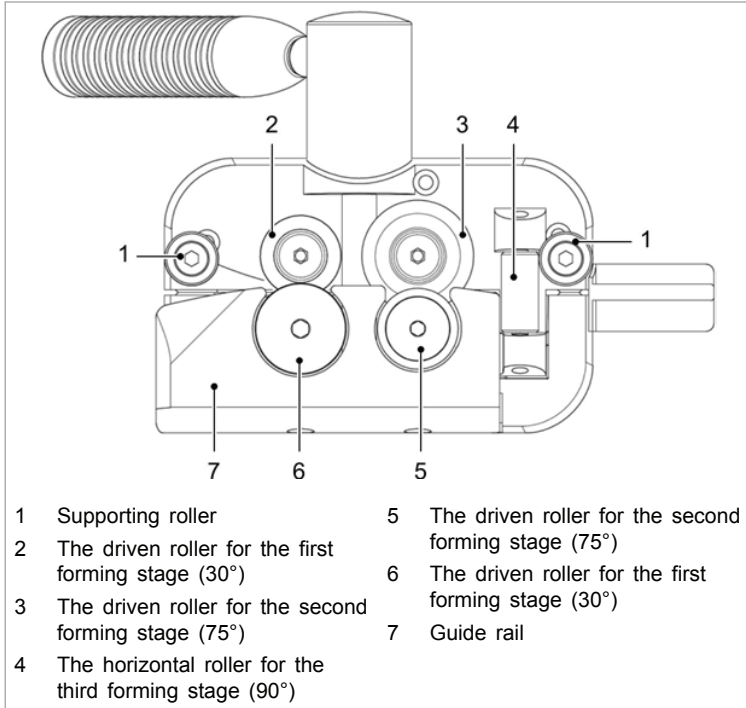

View of the machine from below: the roller arrangement

Fig. 46685

The sequence of the folding process

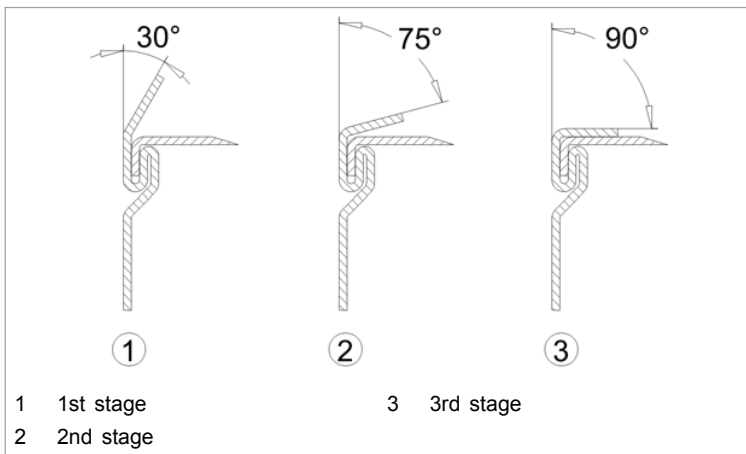

The folding process

Fig. 13416

Note

The flange is formed in 3 stages.

4. Setting work

4.1 Adjusting the tool

To be able to apply the machine to the required place on the channel or to be able to remove it at the end of the channel, the spacing between the rollers and the guide rail can be locked in 2 positions.

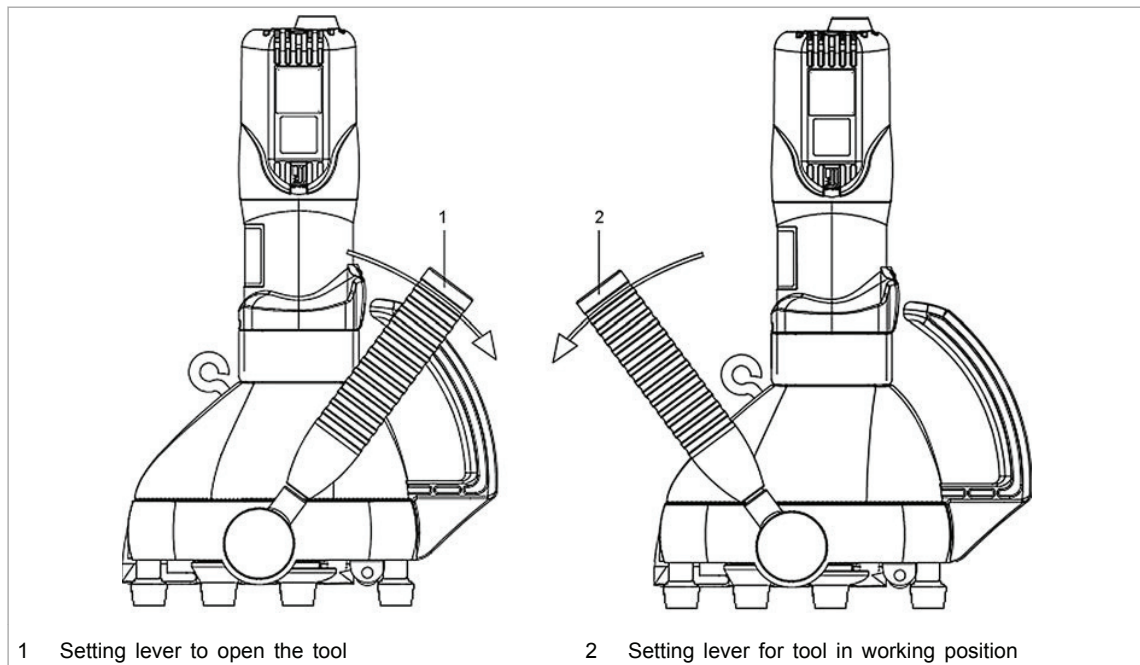

Fig. 69989

Note

It is not necessary to adjust for the thickness of the sheet, as the machine adjusts itself automatically.

- Press the setting lever (1) into position against the feed direction.

The tool is open.

or

- Press the setting lever (1) into its end position in the feed direction.

The tool is in its working position.

5. Operation

 **CAUTION**

Damage to property due to excessively high line voltage

Motor damage

- Check the line voltage. The power supply voltage must correspond to the information on the nameplate of the machine.
 - When using an extension cord that is longer than 5 m, the cord must have a line diameter of at least 2.5 mm².
-

 **WARNING**

Damage to the machine due to improper handling.

- Make sure the machine is always in a stable position when operating it.
 - Never touch the tool while the machine is running.
 - Always operate the machine away from your body.
 - Do not operate the machine above your head.
-

5.1 Work with TruTool F 305

Depending on the type of channel to be machined, there are 2 options when starting work:

- The channel is open.
- There is a flange at the start of the channel.

Switching on

- Slide the On/Off switch down.

The channel is open

To improve the results, lightly oil the rollers or the sheet with universal oil (order number 138648).

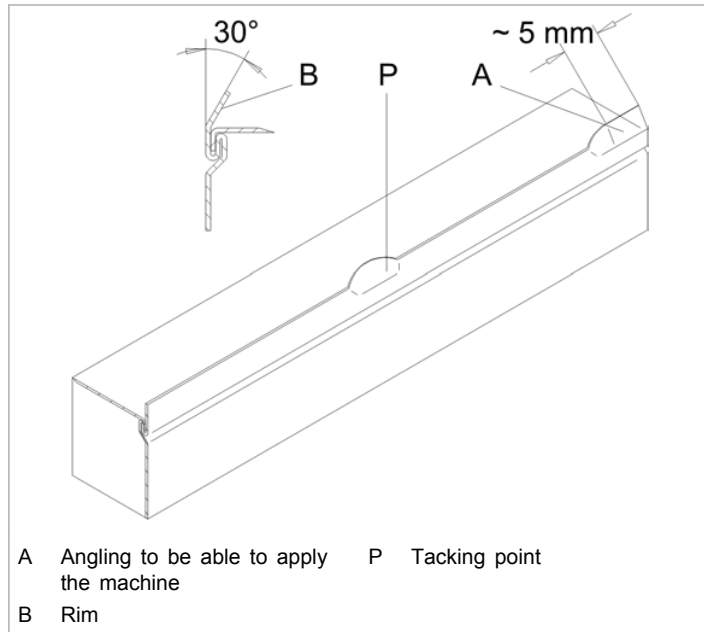

Seam preparation

Fig. 13411

1. Angle the flange to approx. 30° at the start of the channel for a length of approx. 5 mm.

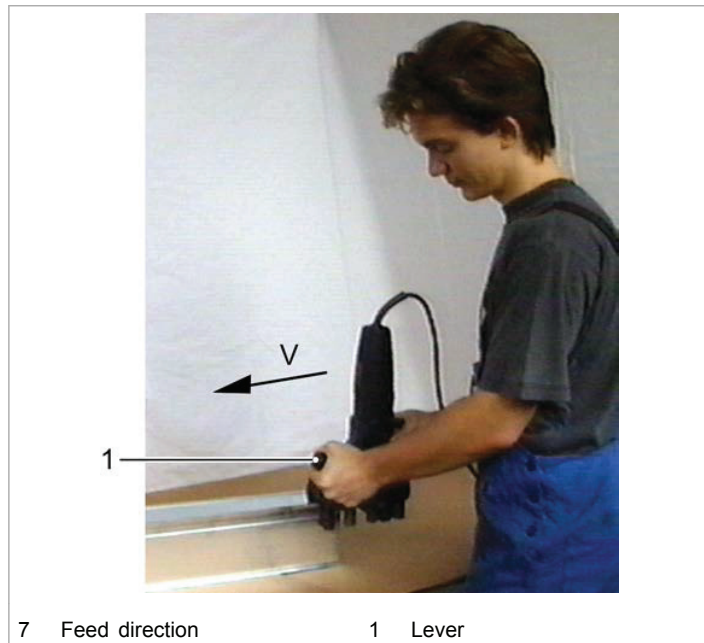

Fig. 13415

2. Put the lever (1) into its end position in the feed direction (tool in its working position).
3. Switch on the machine and apply it to the start of the channel.

Tip

The curved guide rail ensures that the machine can easily be applied when starting machining.

4. The drive rollers pull the machine in the feed direction, i.e. the seam is closed.

There is a flange at the start of the channel.

The machine cannot be applied at the start of the channel. Preparation of the channel so that the machine can be applied.

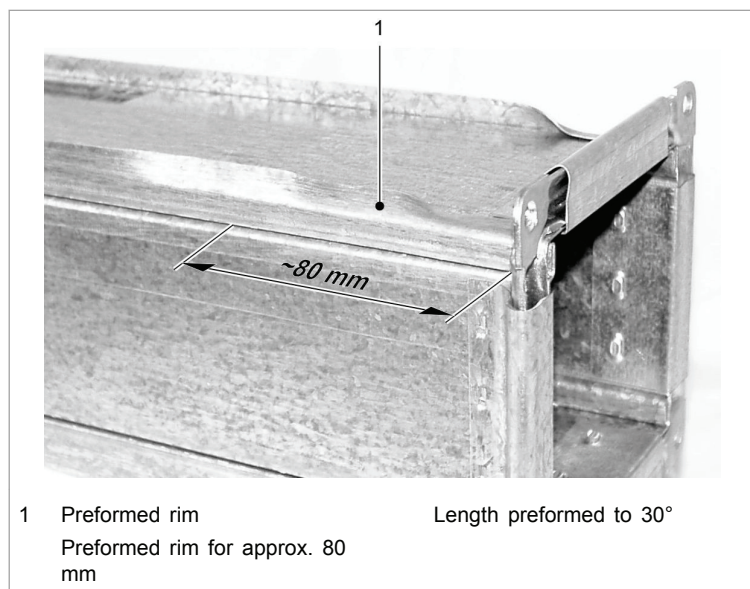

Fig. 18183

1. Put the lever (1, (see "Fig. 13415", pg. 12)) into the position opposing the feed direction (tool open).
2. Apply the machine to the required (prepared) position on the channel.
3. Put the lever (1) into the feed direction (tool in its working position).

The machine's working direction (feed direction) is determined by its design.

4. Switch on the machine.
5. Close the seam.
6. Put the lever (1,) into the tool open position.



Note

At the end of the channel, a small amount of manual follow-up work will be needed at the end of the channel after using the seam locker (for a length of approx. 130 mm).

7. Switch the machine off and remove the tool from the channel.

Switching off

- Slide the On/Off switch upwards.

6. Maintenance



Risk of injury due to incorrect repair work

Machine does not work properly.

- Maintenance may be carried out by trained specialist technicians only.
- Only use original TRUMPF accessories.

Maintenance point	Procedure and interval	Recommended lubricants	Lubricant Order No.
Guide rail and drive pinion	Every 10 operating hours, a technician should clean with a wire brush and oil	Universal oil	138648
Gearbox and gear head	After 300 operating hours, arrange for a technician to add grease or to replace the lubricating grease	Lubricating grease "G1"	0139440
Driver rollers	Clean as needed	-	-
Ventilation slots	Clean as needed	-	-

Maintenance positions and maintenance intervals

Tab. 6

6.1 Tighten the screws to a torque

Components	Torque	Thread lock
30° roller	24 Nm	Loctite 262
75° roller	24 Nm	Loctite 262
Driver roller (30°)	24 Nm	-
Driver roller (75°)	24 Nm	-
Slotted nut	6 Nm ¹	Loctite 262
Cylindrical pin 5 m 6x24 DIN 6325	-	-

Tab. 7

1 The locking mechanism must be closed (special wrench order no. 922759)

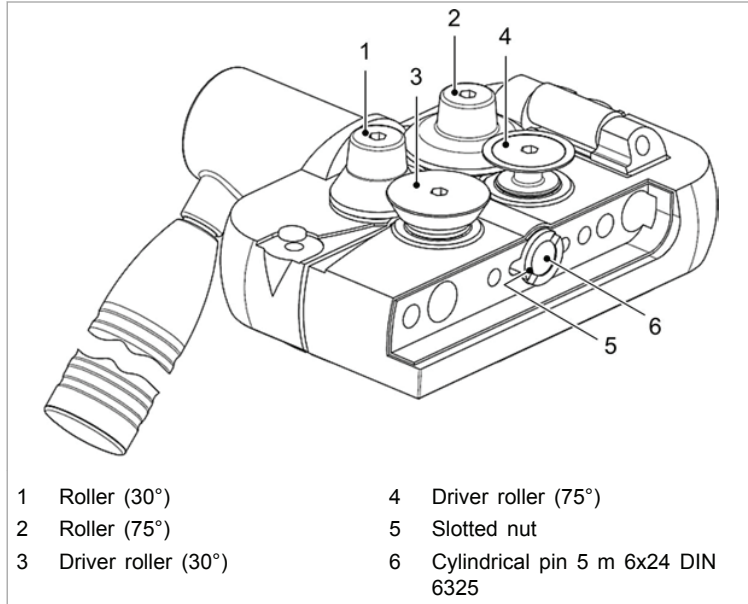

View of the F 305 seam locker from below, the guide rail has been removed Fig. 46688

1. Tighten the screws and nuts with the correct torque, if parts of the machine have been removed.
2. Secure with Loctite 262.

6.2 Replacing carbon brushes

The motor comes to a standstill whenever the carbon brushes are worn out.

Note

For TRUMPF service addresses, see www.trumpf-power-tools.com.

- Change the carbon brushes.

7. Accessories and consumables

Name	Scope of delivery	Consumables	Options	Order number
Guide rail	X	X	-	920881
Driver roller 30°	X	X	-	145769
Driver roller 75°	X	X	-	135478
Roller (horizontal)	X	X	-	135791
Suspension eyelet	X	-	-	107666
Allen key DIN 911-4	X	-	-	067849
Universal oil (0.1 l)	X	-	-	138648
Case	X	-	-	982582
Operator's manual, TruTool F 301 (1A1)	X	-	-	1369682
Safety information, other countries	X	-	-	0125699
Safety information, USA	X	-	-	1239438

Accessories and consumables

Tab. 8

7.1 Ordering consumables

Note

The following data must be specified in order to ensure that parts are delivered correctly and without delay.

1. Specify the order number.
2. Enter further order data:
 - Voltage data
 - Quantity
 - Machine type
3. Specify the complete shipping information:
 - Correct address.
 - Desired delivery type (e.g. air mail, courier, express mail, ordinary freight, parcel post).

Note

For TRUMPF service addresses, see www.trumpf-powertools.com.

4. Send the order to the TRUMPF representative office.

**8. Appendix: Declaration of conformity,
guarantee, replacement parts lists**