

Operator's manual



TruTool N 200 (1A1)

english



Table of contents

1.	Safety	3
2.	Description	5
2.1	Correct use	6
2.2	Technical data	7
3.	Tool assembly	8
3.1	Changing the stroke rate	8
4.	Operation	10
4.1	Working with the TruTool N 200	10
4.2	Changing the cutting direction	11
4.3	Making inner cutouts	11
4.4	Nibbling with templates	12
5.	Maintenance	13
5.1	Changing the tool	14
	Disassembling the punch	15
	Installing the punch	15
	Replacing the die	15
5.2	Replacing carbon brushes	15
6.	Original accessories and wearing parts	16

Warranty

Replacement parts list

Addresses

1. Safety

- USA/CAN** ➤ Read the Operator's Manual and the general safety rules (Material number 1239438, red document) in their entirety before starting up the machine. Follow precisely the directions contained therein.

- Rest of the world** ➤ Read the Operator's Manual and the safety instructions (Material number 125699, red document) in their entirety before starting up the machine. Follow precisely the directions contained therein.
- The safety regulations according to DIN VDE, CEE, AFNOR and other regulations which are valid in individual countries should be adhered to.



Danger

Lethal danger due to electric shock!

- Remove the plug from the plug socket before undertaking any maintenance work on the machine.
 - Check the plug, the cable and the machine for damage each time before the appliance is used.
 - Keep the machine dry and do not operate in damp rooms.
 - When using the electric tool outside, connect the fault current (FI) protective switch with a maximum breaking current of 30 mA.
-



Warning

Danger of injury possible due to improper handling!

- When working with the machine, wear safety glasses, hearing protection, protective gloves and work shoes.
 - Do not plug in the plug unless the machine has been switched off. Pull out the mains plug after use.
-



Warning

Risk of injury to the hands!

- Do not place your hand into the processing line.
-



Caution

Damage to property possible due to improper handling!

The machine will be damaged or destroyed.

- Do not use the power cord to carry the machine.
 - Always guide the electric cord away from the back of the machine and do not pull it across sharp edges.
 - Arrange for start-ups and checks on manual electric tools to be carried out by a trained specialist. Only use the original accessories provided by TRUMPF.
-



Warning

Risk of injury from high-temperature and sharp chips!

High-temperature and sharp chips are expelled from the chip ejector at high speed.

- The use of the chip bag is recommended.
-

2. Description

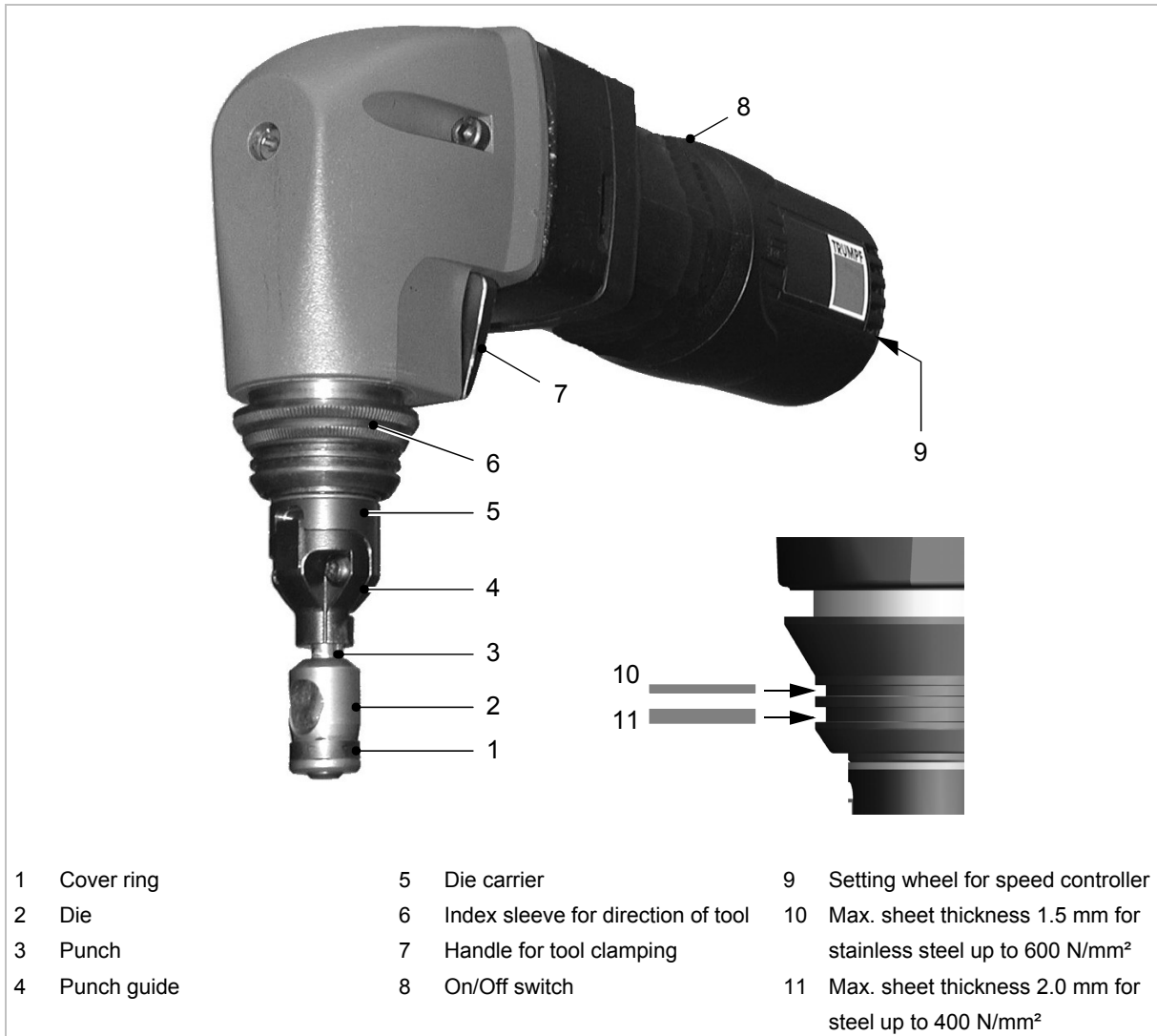

TruTool N 200

Fig. 36729

2.1 Correct use



Warning

Risk of injury!

- For processing and materials, only use machines which are named in "Correct use".

The TRUMPF Nibbler TruTool N 200 is an electric hand tool used for the following applications:

- Slitting plate-shaped workpieces made of a punchable material such as steel, aluminium, non-ferrous heavy metals, and plastic.
- Nibbling straight or curved exterior and interior cutouts.
- Slitting tubes as well as machining sectional sheets.
- Nibbling from scribed lines or templates.

Note

The nibbling process produces cutting edges free of deformations.

Note

- Because of the hollow round punch, the nibbler can be rotated at any position such that processing can continue in any direction.

2.2 Technical data

	Rest of the world			USA
	Values	Values	Values	Values
Voltage	230 V	120 V	110 V	120 V
Frequency	50 Hz	50/60 Hz	50 Hz	50/60 Hz
Steel 400 N/mm²	2.0 mm	2.0 mm	2.0 mm	0.08 in
Steel 600 N/mm²	1.5 mm	1.5 mm	1.5 mm	0.06 in
Steel 800 N/mm²	1.0 mm	1.0 mm	1.0 mm	0.039 in
Aluminium 250 N/mm²	2.5 mm	2.5 mm	2.5 mm	0.1 in
Working speed	1.1 m/min	1.1 m/min	1.1 m/min	3.6 ft/min
Nominal power consumption	500 W	500 W	500 W	500 W
Stroke rate with idle run	2100/min	2000/min	2000/min	2000/min
Weight	2.2 kg	2.2 kg	2.2 kg	4.9 lbs
Start hole diameter	16 mm	16 mm	16 mm	0.630 in
Smallest radius with curved cutouts	4 mm	4 mm	4 mm	0.16 in
Protective insulation	Class II	Class II	Class II	Class II

Technical data

Tab. 1

Noise and vibration	Measured values in accordance with EN 60745
A-weighted sound level	Typically 81 dB (A)
A-weighted acoustic power level	Typically 85 dB (A)
Hand-arm vibration	Typically 3.5 m/s ²

Measured values for noise and vibration

Tab. 2

Note

The measured values specified above may be exceeded while working.

3. Tool assembly

3.1 Changing the stroke rate



Caution

Damage to property possible resulting from stroke rate being too low!

The motor could be damaged due to overheating!

- Select suitable stroke rate.

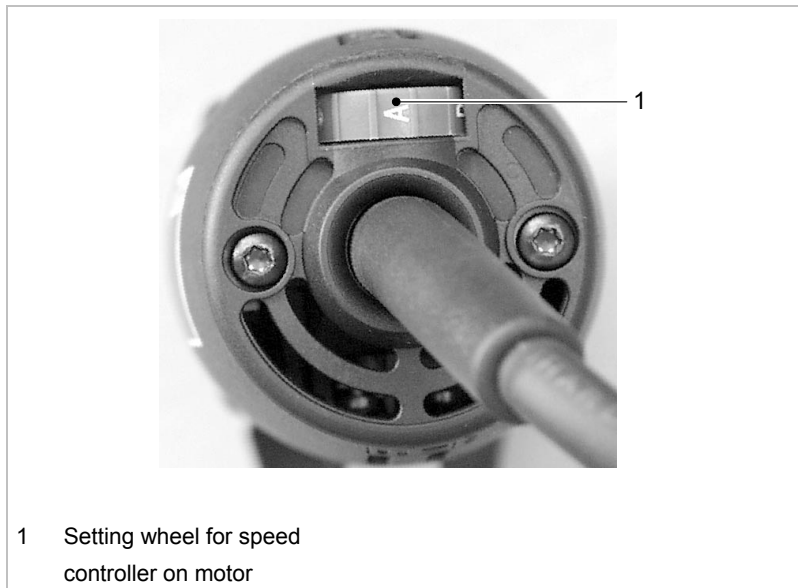

1 Setting wheel for speed controller on motor

Speed controller

Fig. 25263

Reducing the stroke rate

- Rotate the setting wheel for the speed controller counter-clockwise.

A reduced number of strokes improves the quality of the work

- for precise machining along scribed lines.
- for machining radiuses.
- for machining steel with a tensile strength $> 400 \text{ N/mm}^2$ (improved service life).

Note

The rpm cannot be adjusted with the 120 Volt version. Work is always performed at the maximum rpm.



Sheet thickness [mm]	max. tensile strength [N/mm ²]	Speed controller	
		Continuous operation	Intermittent operation
0.5		G-D	C-A
1	800 (stainless steel)	G-E	D-B
1.5	600 (stainless steel)	G-F	E-C
2	400 (steel)	G	F-D
2.5	250 aluminium	G	F-E

Tab. 3

4. Operation

4.1 Working with the TruTool N 200



Caution

Damage to property possible due to too-high network voltage!

Damage to the motor!

- Check the power supply. The power supply must correspond to the information on the machine type plate.



Warning

Danger of injury possible due to improper handling!

- When working with the machine, always ensure that it has a secure base.
- Never touch the tool while the machine is running.
- Always guide the machine away from the body while working.
- Do not work holding the machine above your head.

Switching on the TruTool N 200

- Move the On/Off switch to the front.

Note

The cutting result is improved and the service life of the punch increased if the cutting track is coated with oil before machining the workpiece.

Material	Oil
Steel	Punching and nibbling oil, Order No. 103387
Aluminium	Wisura oil, Order No. 125874

Tab. 4

Working with the TruTool N 200

1. Do not move the machine towards the workpiece until full speed has been reached.
2. Machine/process the material.
 - Machine the desired cutting line.
3. In the event that the cutting track ends in the sheet, pull the still-running machine a few millimetres back towards where the cutting track has already been cut open.
4. Switch the machine off.

Switching off the TruTool N 200

- Move the On/Off switch to the rear.

4.2 Changing the cutting direction

The direction of the cut can be rotated to the right or the left in 5° increments as needed.

- For right-handed/left-handed operation.
- Machining sectional sheets.

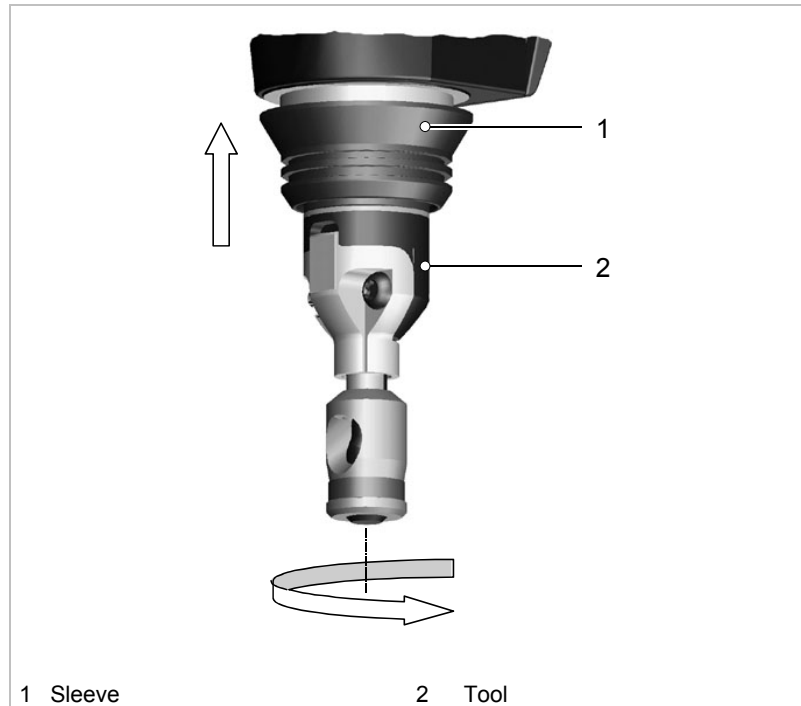

Fig. 25666

1. Push the sleeve (1) up until it stops.
2. Turn the tool (2) to the desired direction.
3. Release the sleeve (1) and turn the tool (2) slightly such that it locks into the next index position.

4.3 Making inner cutouts

- Make a start hole at least 16 mm in diameter.

4.4 Nibbling with templates

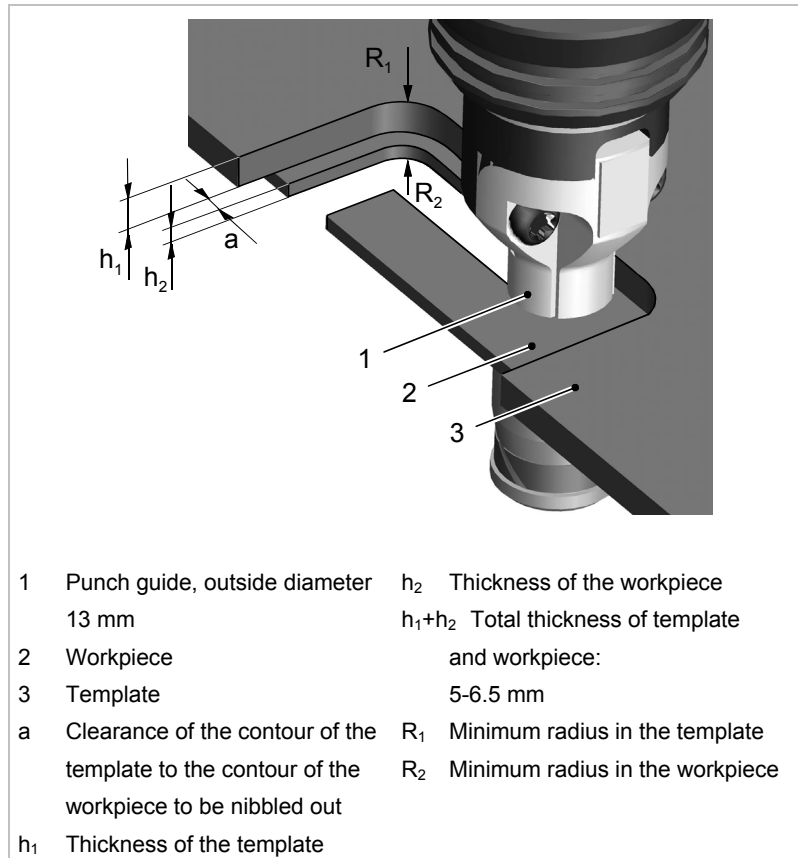

Fig. 25828

5. Maintenance



Danger

Possible lethal danger due to electric shock!

- Pull the plug out of the socket when carrying out tool changes and before all maintenance work on the machine.



Caution

Damage to property possible due to blunt tools!

Overloading of the machine.

- Check the cutting edge of the punch hourly for wear. A sharp punch provides good cutting performance and is easier on the machine. Replace punches promptly.



Warning

Risk of possible injury due to improper repairs!

The machine does not function properly.

- Repairs should be carried out only by a trained specialist.

Maintenance point	Procedure and time interval	Recommended lubricants	Order No. Lubrication agents
Punch guide	With each tool change	Lubricating grease "G1"	121486
Gearbox and gear head (2)	After 300 operating hours, arrange for a trained specialist to relubricate or to replace the lubricating grease	Lubricating grease "G1"	139440
Punch	Replace as needed	-	-
Die	Replace as needed	-	-
Ventilation slots	Clean as needed	-	-

Maintenance positions and maintenance intervals

Tab. 5

5.1 Changing the tool

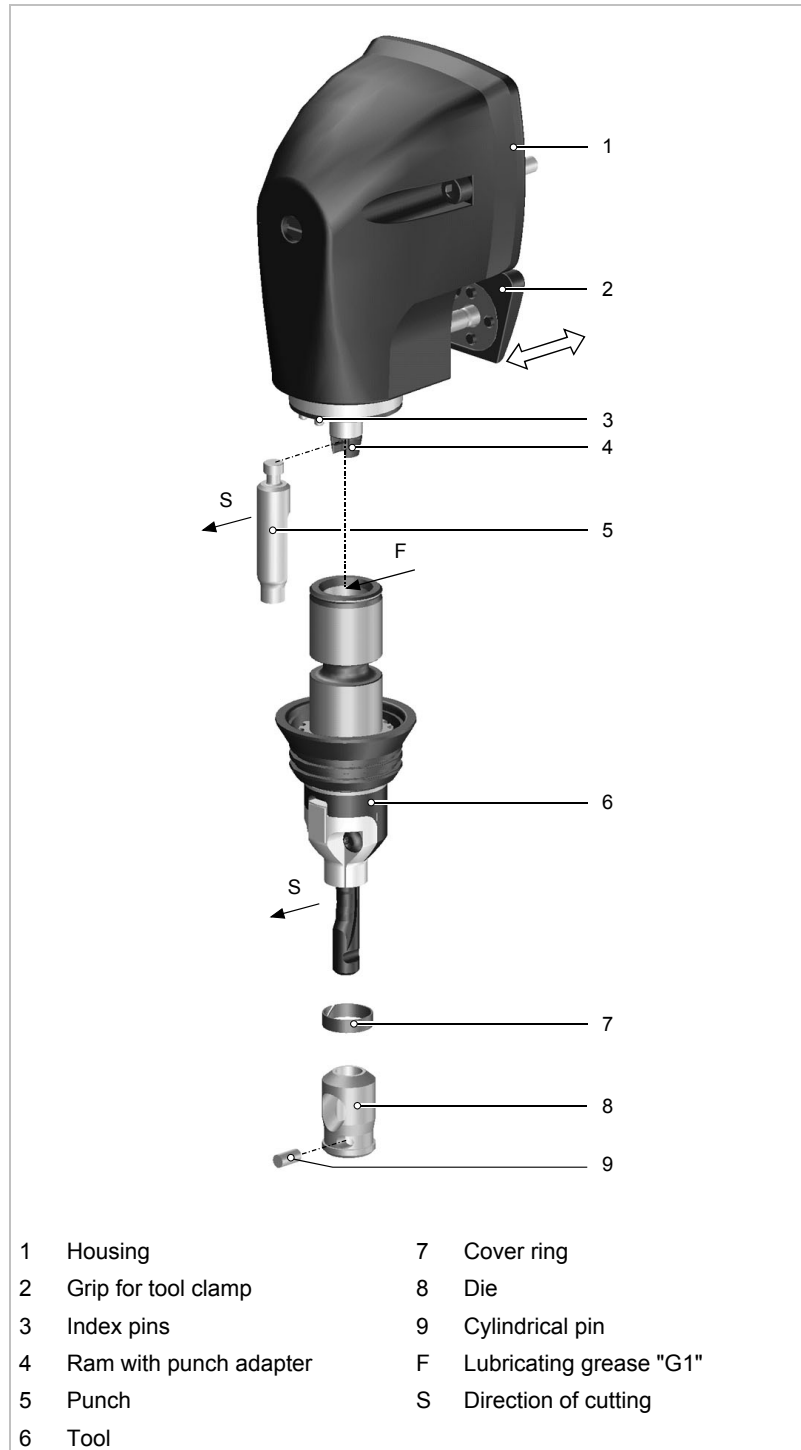

Fig. 25655

- If the punch or die becomes blunt, change the tool.



Disassembling the punch

1. Pull handle (2) back.
2. Pull tool (6) out of the housing (1).
3. Remove punch (5).

Installing the punch

1. Lightly lubricate the punch (5) and the boring in the tool (6) with lubricating grease "G1".
2. Hang the punch in the groove of the punch adapter.
3. Align the cutting direction towards the front.
4. Insert tool (6) into the housing (1) with cutting direction facing towards the front.
5. Slide handle (2) back, the tool (6) is kept in the housing.

Replacing the die

1. Push cover ring (7) upward out of slot.
2. Push out cylindrical pin (9) using a drift punch.
3. Pull off die (8) from the carrier pin and replace it with a new die.
4. Set die on the carrier pin.
5. Mount cylindrical pin.
6. Slide the cover ring in the nut downwards.

5.2 Replacing carbon brushes

The motor comes to a standstill when the carbon brushes are worn out.

- Have the carbon brushes checked and replaced as needed by a trained technician.

Note

Only use original replacement parts and take note of the information on the rating plate.

6. Original accessories and wearing parts

Designation	Original accessories delivered	Wearing parts	Optional	Material-number
Punch	+	+		944506
Die	+	+		994799
Lubricating grease "G1" Tube	+			344969
Case	+			345243
Operator's manual	+			1254080
Safety information (red document), other countries	+			125699
Safety information (red document), USA	+			1239438
Chip bag			+	088622
Punching and nibbling oil for steel (0.5 litre)			+	103387
Torx Spanner Tx20			+	0359907
TruTool PN 200 (1A3), (1A4)			+	961964
TruTool PN 161 (1A3)			+	961966

Original accessories, wearing parts and optional items

Tab. 6

Ordering wearing parts To ensure fast delivery of the correct original and wearing parts:

1. Give the order number.
2. Enter further order data:
 - Tension data
 - Number of pieces
 - Machine type
3. Give complete dispatch data:
 - Correct address.
 - Required delivery type (e.g. air mail, courier, express mail, ordinary freight, parcel post).
4. Send the order to the TRUMPF representative office. For TRUMPF service addresses, see the address list at the end of the document.