

## 10 Spare parts list

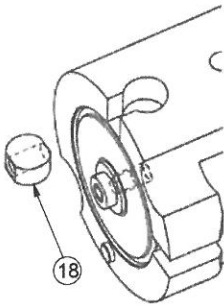
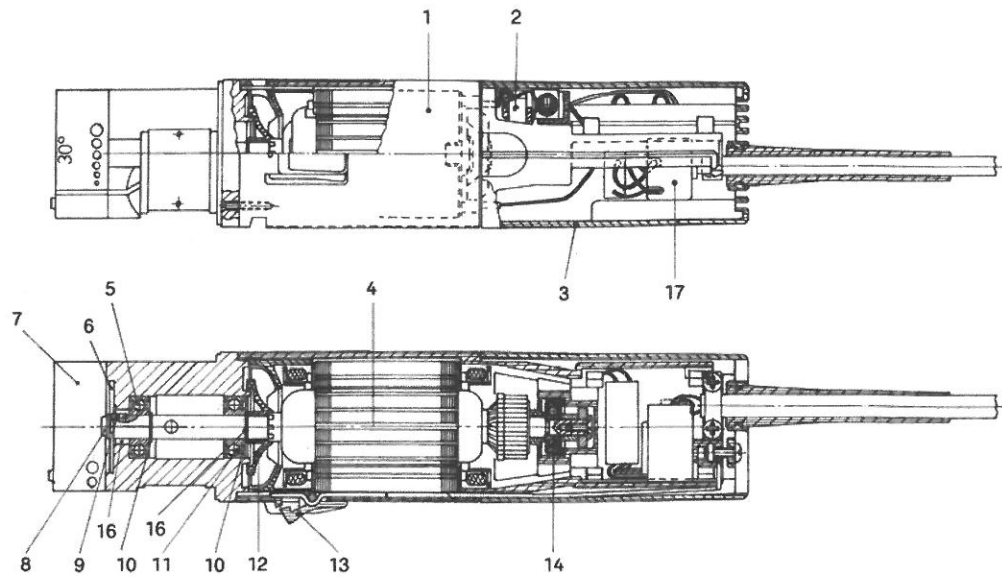

| Item No. | Part Number | Quan. | Description   |   |
|----------|-------------|-------|---|---|
| 1        | 790 052 526 | 1     | Electric motor 230 V, 50/60 Hz (including motor flange) |   |
| 2        | 790 052 528 | 2     | Carbon brush 230 V                                      |   |
|          | 790 052 538 | 2     | Carbon brush 120 V                                      |   |
| 3        | 790 052 633 | 1     | Switch cap  |   |
| 4        | 790 052 549 | 1     | Rotor 230 V with vent                                   | Rotor comes with:<br>1 x Bearing (Part no. 790 093 264)<br>1 x Bearing underside (Part no. 790 052 630)<br>1 x Bearing upper side (Part no. 790 052 631)<br>2 x Retainer (Part no. 790 052 632) |
|          | 790 052 649 | 1     | Rotor 110 V with vent                                   |   |
| 5        | 790 052 631 | 1     | Bearing (upper side)                                    |   |
| 6        | 790 052 487 | 1     | Diamond grinding wheel, fine                            |   |
|          | 790 052 488 | 1     | Diamond grinding wheel, medium                          |   |
|          | 790 052 550 | 1     | Diamond grinding wheel, coarse                          |   |
| 7        | 790 052 530 | 1     | Grinding head 15°; 18°; 22,5°; 30°                      |   |
|          | 790 052 540 | 1     | Grinding head 15°; 30°; 45°; 60°                        |   |
| 8        | 790 052 531 | 1     | Cylinder head screw with washer M4x6                    |   |
| 9        | 790 052 533 | 1     | Cylinder pin Ø 2  |   |
| 10       | 790 052 632 | 2     | Retainer  |   |
| 11       | 790 052 630 | 1     | Bearing (underside)                                     |   |
| 12       | 790 052 541 | 1     | Vent*   |   |
| 13       | 790 052 542 | 1     | On/Off switch   |   |
| 14       | 790 093 264 | 1     | Bearing   |   |
| 16       | 790 052 599 | 1     | Protection  |   |
| 17       | 790 052 604 | 1     | Switch  |   |
| 18       | 790 052 559 | 1     | Nut M4 DIN 934  |   |
| -        | 790 052 534 | 1     | Cylinder head screw M4x15 with nut M4 DIN 934           |   |

\* Attention: The rotor shaft has to get balanced after exchanging the vent. Danger at 30,000 rpm.

### Additional spare parts for ESG Plus<sup>2</sup> (Double-Decker Kit)

| Item No. | Part Number | Quan. | Description                                   |
|----------|-------------|-------|---|
| -        | 790 052 530 | 1     | Grinding head 15°; 18°; 22,5°; 30° (Standard) |
| -        | 790 052 540 | 1     | Grinding head 15°; 30°; 45°; 60° (optional)   |
| -        | 790 052 550 | 1     | Diamond grinding wheel, rough                 |
| -        | 790 052 536 | 1     | Cylinder head screw with collar M4x34         |
| -        | 790 052 537 | 1     | Shaft elongation                              |