

INSTRUCTION MANUAL

ELECTRIC CHAMFERING TOOL

Please read this manual carefully before you attempt to use your tool so that you may use it properly and safely.

HAND BEVELER Model HB-15B PROFESSIONAL TOOL

HB-15B

Specifications

Model		HB-15B	
Power Source (Single Phase)		110 V-120 V AC 60 Hz	220 V-240 V AC 50 Hz
Rated Power Consumption		910 W	
Rated Current		10.5 A	4.0 A
Rated Time		Continuous	
Rated Speed (No Load)		3,340 min ⁻¹	2,750 min ⁻¹
Chamfering Capacity		0 C to 15 C	
Chamfering Angle		15° to 45°	
Mass (Weight)		14 kg	
Sound Pressure Level	No Load	64 dB(A)	
	Load	90 dB(A)	
Sound Power Level	No Load	74 dB(A)	
	Load	101 dB(A)	
Vibration Level (According to ISO20643)	Load	T Handle	0.97 m/s ²
		Sub Handle	1.40 m/s ²

Due to continuous product development/improvement the specifications and configurations in this document are subject to change without prior notice.



Manufactured by :

NITTO KOHKI Co., Ltd.
2-9-4, Nakaikegami, Ohta-ku,
Tokyo, 146-8555, Japan
TEL : (81)-3-3755-1111
FAX : (81)-3-3753-8791
E-mail : overseas@nitto-kohki.co.jp
URL : www.nitto-kohki.co.jp

Keep the manual handy – so you can use it whenever necessary.

Thank you very much for your purchase of this **Nitto Kohki products**.

Before using your tool, please read this manual carefully so that you may use it properly to get the most out of it.

Please keep the manual handy - so you can use it whenever necessary.

- **English** : Please ask your dealer or distributor for instruction manual in local language(s).
- **German** : Bitte fragen Sie Ihren Händler nach eine Betriebsanleitung in Landessprache.
- **French** : S'il vous plait, veuillez demandez á votre fournisseur de manuel instruction en langue locale.
- **Spanish** : Por favor, contacte con su distribuidor para el manual de instrucciones en español.
- **Portuguese** : Por favor pessa ao seo agente ou distribuidor o manual de instrucces ih linguagen local.
- **Italian** : Per Manuale Istruzioni in lingua locale Vi preghiamo di rivolgervi al rivenditore o distributore.
- **Dutch** : Vraag uw handelaar om een nederladstalige gebruiksaanwijzing.
- **Swedish** : Be er lokala Åtreförsäljare eller distributör om manualer på svenska.
- **Danish** : Venligst henvend Dem til den danske distributør for instructions manualer.
- **Polish** : Prosze pytac swojego dealera lub dystrybutora o instrukcje obslugi w jezyku localnym.
- **中文** : 請向當地供應商或經銷商詢問中文使用說明書

CONTENTS	page
IMPORTANT SAFETY INSTRUCTIONS	2
GENERAL: TOOLS	2
GENERAL: POWER TOOLS	3
INSTRUCTIONS FOR THIS TOOL	4
1. USAGE	4
2. CHECK THE CONTENTS OF THE PACKAGE	4
3. PREPARATIONS	4
4. HOW TO OPERATE THE TOOL	6
5. HOW TO REPLACE INDEXABLE INSERTS AND THE HOLDERS	6
6. MAINTENANCE AND INSPECTION	7
7. CONDITION FOR USE	7
8. ORDERING SERVICE PARTS	7
9. OPTIONAL PARTS	7
10. EXPLODED DIAGRAM : HB-15B	8

PICTOGRAM



Warning: It might be dangerous to operate the tool if the instructions supplied are not followed.



Using this tool improperly could result in serious injury. Read the instruction manual before using.



Always wear suitable eye protection.



Always wear suitable hearing protection.



Always wear respiratory protective equipment (PPE).



Always wear protective gloves for protection of hands from Vibration, Shock and Burns.

Storage Temperature :	-10°C - 60°C (no freezing)
Storage Humidity :	Maximum 90% at 25°C (no dewing)
Operating Temperature :	5°C - 40°C
Operating Humidity :	Maximum 90% at 25°C (no dewing)
Altitude :	1000m Max.
Over-voltage Category :	Category II according to IEC60664-1
Pollution Degree :	Degree 3 according to IEC60664-1

The following Safety notations are used throughout the manual to highlight safety precautions for the user and for the tool.

	WARNING: Indicates a potentially hazardous situation which, if not avoided by following the instructions given, could result in death or serious injury.
	CAUTION: Indicates a potentially hazardous situation which, if not avoided by following the instructions given, could result in injury or material damage.

Please note, however, that failure to observe safety precautions under the “ **Caution**” category could result in a serious occurrence depending on the situation: please observe all safety precautions in the manual.

Caution: Important precautions for tool setup, operation and maintenance.

IMPORTANT SAFETY INSTRUCTIONS

When using the tool, please observe the safety precautions below to prevent possible accident or injury.

GENERAL: TOOLS

WARNING

TO OPERATORS

- **Wear proper clothing for the type of work being done.**
Take care so that clothing, ties, hair, etc. will not become entangled with the moving parts. If items become entangled, it will cause the operator to be pulled towards the tool and lead to possible cause of accident or injury.
- **Always wear suitable eye protection.**
Remember, regular glasses are not safety glasses. The lenses are only shock resistant, which will not give you sufficient eye protection you may need in your working environment.
- **Always wear suitable hearing protection.**
- **Wear respiratory protective equipment (PPE).**
Wear respiratory protective equipment (PPE) when working in an environment where dust particles are generated in operation.
- **Always wear protective gloves for protection of hands from vibration, shock and burns.**
- **Avoid working posture that is too stressful.**
Always ensure a firm footing and well balanced posture.
- **Do not operate the tool if you are too tired.**
- **Never touch any moving parts of the tool when running.**

ABOUT WORK AREA

- **Keep the work area clean.**
Cluttered work areas (e.g. workbench) invite accidents.
- **Carefully select the work area.**
Do not expose the tool to rain.
Do not use the tool in a wet or soaked area.
See that the work area is adequately illuminated.
- **Never work near inflammable liquid or in a potentially explosive atmosphere.**
- **Keep children away from the work area.**
Keep children and unauthorized people away from the work area to avoid accident or injury.

BEFORE OPERATION

- **Inspect tool before use.**
Before using, check that screws are securely tightened, that any protective cover or guard is securely in place and other parts are free from damage, and that the tool runs as it should.
Check that moving parts are properly adjusted for positioning and tightened, that parts are free from damage and properly mounted, and that all other parts are in good condition for normal operation.
Should you find any damage to the protective cover or other part, replace it in accordance with the Operation Manual. If there are no instructions in the Manual, please contact the sales agent through which you have purchased your tool or an authorized dealer near you for repair.
Likewise, if a switch failure occurs, contact sales agent through which you have purchased your tool or an authorized dealer near you for repair.
Do not use the tool if it does not start or stop with the start/stop switch.
- **Securely mount cutter**
An improperly mounted cutter may fly out, causing possible damage to the tool or injury to the operator.
- **Always remove spanner, wrench, etc., once adjustment has been made with them.**
- **Use a tool appropriate for the application.**
Avoid heavy-duty application that is beyond the capacity of the tool.
- **Do not use the tool for purposes other than what it is designed for.**
- **Do not abuse tool.**
Use the tool in accordance with the specifications: you'll get the most out of it while ensuring safety.
- **Securely fasten workpiece in place.**
Use a vice or clamp to securely fasten the workpiece in place. It is much safer this way than holding it in your hand, allowing you to operate the tool with both hands.

ABOUT HANDLING

- **How to store tool.**
When the tool is not used, store it in a dry area and out of reach of children.
- **How to carry tool.**
Do not touch the start switch while the tool is being carried.
- **Do not leave the tool unattended while it is running.**
Turn off the start switch and disconnect the tool from power source. Do not leave the work area until the tool comes to a complete stop.

MAINTENANCE/SERVICE

- **Do not take apart or modify tool.**

Disassembly or modification carried out without the supervision of a qualified or authorized service engineer could result in an accident or injury.

- **Inspect cutting tool and accessories, etc.**

Always check to see that the cutting tool and accessories, etc. are in good operating condition without damage or deterioration before you mount them on the tool. Should you find any damage to an accessory or part, please contact sales agent through which you have purchased your tool or an authorized dealer near you for repair.

- **Check parts for damage.**

When you have found damage to the accessory or other part, carefully check the damaged part to determine the extent of influence it has upon the functions of the tool – that is, determine whether it can still perform its normal functions.

Check to see that the linkage of the moving parts is OK, that all parts are OK without damage, that they are properly mounted, and that the tool functions normally. Should you find any damage to an accessory or part that may hamper proper functioning of the tool, please contact sales agent through which you have purchased your tool or an authorized dealer near you for repair.

- **Have your tool repaired at an authorized Nitto Service Center.**

For repair or parts replacement, please contact the sales agent through which you have purchased your tool or an authorized dealer near you.

- **Use only Nitto genuine parts.**

Use of improper parts may result in serious accident. To obtain a Nitto genuine part, consult this Manual or contact the sales agent from which you have purchased your tool directly.

- **Do not detach label or nameplate from tool.**

When a label/nameplate gets damaged, worn or becomes missing, contact the sales agent through which you have purchased your tool or Nitto Kohki Co. Ltd, directly for a replacement.

DISPOSAL

When a tool is taken permanently out of service, it is advised that the tool is disassembled, degreased and parts separated by material and recycled locally in the appropriate manner.

GENERAL: POWER TOOLS

WARNING

- **Always use power source per specifications on the nameplate.**
- **Never connect the earthing conductor to a gas Pipe: if you do so explosion may result.**
- **Check to see that there is no abnormality in earth- clipping or earthing conductor.**

Conduct continuity check between the earth clip and a metal portion of the machine with a tester or insulation resistance tester, if you have one. Wiring connections involving the installation of earth bar or plate into the ground will call for the expertise of a qualified electrician. Please contact your local electrical contractor.

- **Don't abuse cord.**

Don't carry tool with a cord in your hands; don't pull a cord to disconnect it from the socket. Don't give damage to cord by abusive use, such as, reworking, forced bending, exposure to heat, pulling, twisting, bundling, application of weight, pinching, hanging from metal hardware, etc.

- **Before using the tool, ensure that ground-fault circuit interrupter for electrical shock guard is installed in the power source to which the tool will be connected, as required by the Ordinance on Labor Safety and Hygiene and/or the Technical Standard for Electrical Installation.**

- **Avoid abrupt, unintentional start.**

Before connecting a power supply plug to power source, make sure that the switch is turned off.

- **Turn off the switch and disconnect the power supply plug from power source before setting up for operation or getting down to inspection or maintenance work.**

- **Do not replace the supply cord.**

When replacing the supply cord, please contact the sales agent through which you have purchased your tool or an authorized dealer near you.

INSTRUCTIONS FOR THIS TOOL

About Your Tool

⚠️ WARNING

- Use of power is limited to the power source specified by the rating plate.
- Before using the tool, make sure the power source to which it will be connected is fitted with an earth leakage breaker to prevent electric shock.
- Extension cord should be selected after ensuring the diameter is compatible with the length of the extension.

Beware of extremely long power cord (particularly wound up thin cords) as they may cause drops in voltage which weaken the magnetism, adversely affecting the performance and function of the unit. Do not share the extension cord with any other electric machine tools.

Extension Cord	
Max. Length	Nominal cross-sectional area
10 m	1.25 mm ² or more
15 m	2.00 mm ² or more
30 m	3.50 mm ² or more

- When performing maintenance, inspection, replacement or adjustment of parts, make sure to disconnect the attachment plug from the receptacle.
- To replace the Indexable Inserts after using, do not touch with bare hands as the Indexable Inserts and Holders are heated at high temperature.
- Use our original Indexable Insert.
- Do not use the worn or damaged Indexable Insert.

1 USAGE

This is a hand held electric tool for chamfering of mild steel (SS400) with the Indexable Inserts.

2 CHECK THE CONTENTS OF THE PACKAGE

Check the contents and make sure that the tool does not have any damage which may have occurred during transportation. The contents should correspond to the list as follows. In case of damage/missing parts, please contact the sales agent from whom you purchased the tool.

Package Contents	Qty	check
HAND BEVELER HB-15B	1 set	
Indexable Insert 12.7 Ass'y(12pcs. / Set)	1 set	
Roller Bracket Ass'y	1 set	
Hex. Socket Screw Key 4	1	
Hex. Socket Screw Key 5	1	
Hex. Socket Screw Key 6	1	
Spanner 24 x 27	1	
Hook Spanner 25 x 28	1	
T Wrench Key	1	
Spacer A	1	
Spacer B	1	
Plate B	1	
Instruction Manual	1	
Declaration of Conformity	1	

3 PREPARATIONS

⚠️ WARNING

- Be sure to turn the switch OFF and remove the power plug from power supply whenever setting up the tool.

3-1. How to Adjust Chamfering Levels

- (1) Loosen the Clamp Lever. (Fig.1) Move the Clamp Lever to a convenient position when a spline is used. Move it to a place where it will not obstruct work after use.
- (2) Move the Base Line to the desired location on the Scale Plate by operating the grip so that the specified chamfering levels are obtained.
- (3) Perform firm locking by the Clamp Lever on completion of adjustment, and turn the Clamp Lever to a position where the operation is not obstructed.

* The Clamp Lever has been fixed at an arbitrary position when turned and lifted.

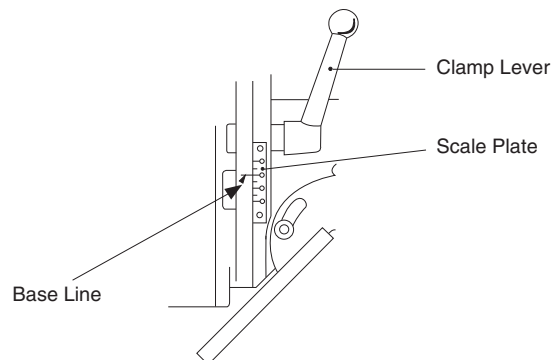

Fig. 1

- (4) Suggestion for performing major chamfering. Carry out chamfering gradually with repeated actions rather than attempting to chamfer every thing at one time. This reduces the labor required as well as the Indexable Inserts wear.

Chamfering levels	Work criteria
7C	7C 1 time
10C	7C → 10C 2 times in total
15C	7C → 10C → 12C → 15C 4 times in total

Table.1

The Scale Plate is for reference only. If accurate chamfering is required, set the tool at a chamfering level about 0.5 smaller than the desired one. Try a test cut. Then adjust the tool for accurate chamfering.

3-2. How to Adjust Chamfering Angle

- (1) Loosen Hex. Socket Head Bolt 6 x 25 on Plate Guide located on both sides of the body. (Fig.2)

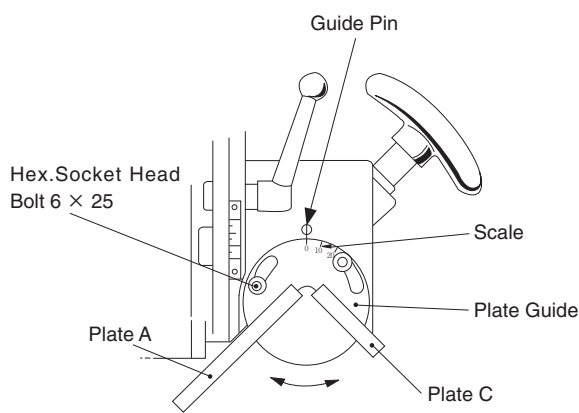

Fig. 2

- (2) Hold the Plates and set the Scale of the Plate Guide at the desired angle (pointed at by the Guide Pin)
 - (3) Fix the Plate Guide in position by tightening the Hex. Socket Head Bolt 6 x 25.
- The tool has the limit of chamfering width which depends on a chamfering angle. (Fig.3, Table.2)

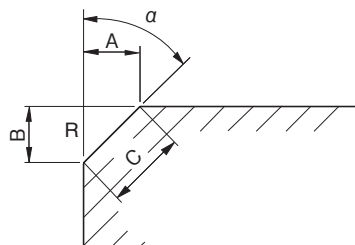

Fig. 3

Chamfering Angle α	A	B	C
45°	15	15	21
30°	9	15.5	18
15°	4	15.4	16

Table.2

3-3. Use of Spacers A and B

When Spacers A and B included in the accessories are mounted as shown in Fig.4, chamfering 7C or less can be performed using six "Indexable Insert 12.7".

* If the setting is made in this manner, it is not possible to perform chamfering of more than 7C.

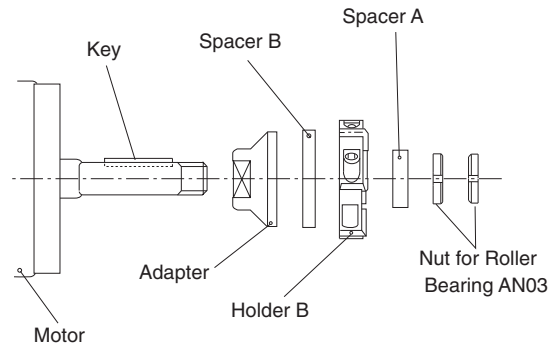

Fig. 4

3-4. Chamfering procedure for a column

Replace Plate C attached to the body with Plate B (included in the accessories).

Mount the Roller Bracket to the Plate B using a Hex. Socket Head Bolt 8 x 30 as shown in Fig.5 and then adjust dimension A (Fig.6).

Chamfering of rounded portions can be performed to accurate finish.

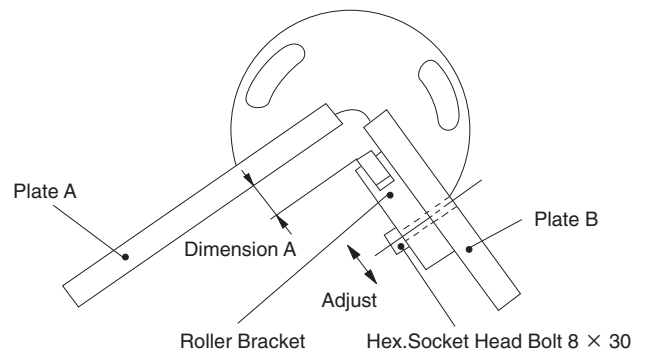

Fig. 5

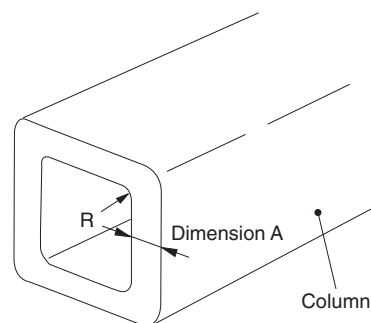

Fig. 6

4 HOW TO OPERATE THE TOOL

⚠ WARNING

- Always wear suitable eye protection, suitable hearing protection, protective gloves, and respiratory protective equipment.

4-1. Start and Stop

⚠ CAUTION

- Always be sure the unit is in the OFF position before plugging the power cord into an outlet.

Placing the switch in the ON position initiates operation. Turn the switch to the OFF side to stop operation.

4-2. Feeding Speed

Operate it at an appropriate speed (30cm/min for mild steel 7C chamfering). If the work surface is burnt, it means the feeding speed is not appropriate. Operation at high feeding speed or with shock will cause damage to the Indexable Inserts or the tool. If cutting chips are burnt at the appropriate speed, visually check the wear condition of the Indexable Inserts and replace it with a new one if worn.

4-3. How to Operation

Hold T Handle and Sub Handle tightly.

Press the tool to a workpiece slowly and move with arrow direction shown in the rating plate.

5 HOW TO REPLACE THE INDEXABLE INSERTS AND THE HOLDERS

⚠ WARNING

- Be sure to turn the switch OFF and remove the power plug from power supply whenever replacing the Indexable Inserts and the Holders.
- The Indexable Inserts and the Holders are much heated right after the operation. Always wear gloves in handling the Indexable Insert and the Holder.

5-1. How to Replace the Indexable Inserts

- (1) Remove Hex. Socket Head Bolt (Fig.7) and pull it out to the direction as shown of the arrow. (Fig.8)

Hex.Socket Head Bolt
6 × 25

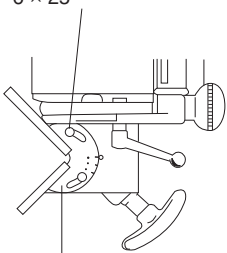

Plate Guide

Fig. 7

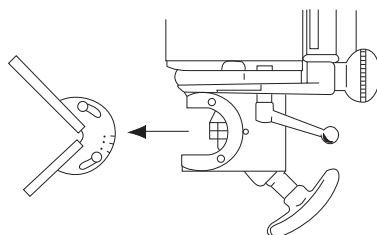

Fig. 8

- (2) Loosen Hex. Socket Head Set Screw 6x8 with a Wrench. Take out an Indexable Insert.

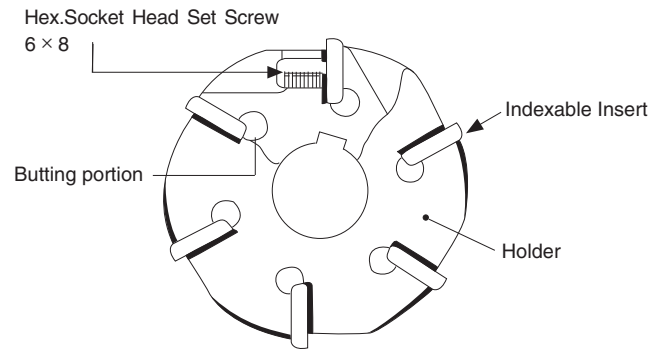

Fig.9

- (3) Remove chips. Insert the Indexable Insert into the Holder, paying attention to the shape of the Indexable Insert. Fix the Indexable Insert with the Hex. Socket Head Set Screw 6 x 8. (Fig.10)

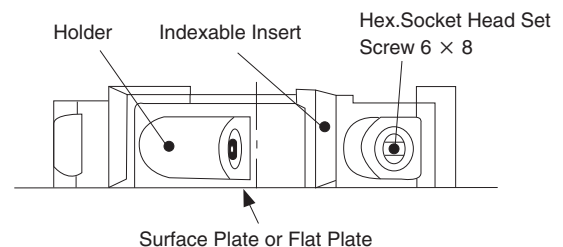

Fig.10

Recognize that the downward edges of the Indexable Inserts are exact on the flat surface of the Holder. Bad alignment may cause breakage of the Indexable Inserts. (Fig.11)

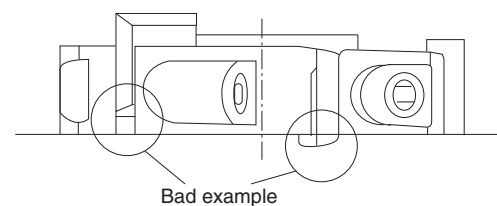

Fig.11

5-2. How to Replace the Holder

- (1) Separate the Motor Unit from the body as shown in Fig.12. (Remove the Clamp Lever and then remove Hex. Socket Head Bolt 8 x 30 on the back side for this purpose.)

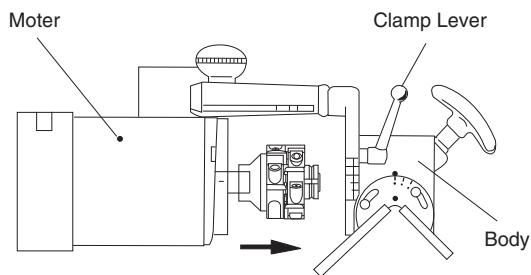

Fig.12

- (2) Remove the Nuts for Roller Bearing shown in Fig.13 using the Spanner and Hook Spanner included in the accessories, and then extract the Holders A and B in the direction of the arrow.
- (3) Mount the Holders A and B in the proper direction (so that projected portions of the Holders A and B face each other), and then firmly tighten the Nuts for Roller Bearing using a Hook Spanner. (Fig.13)

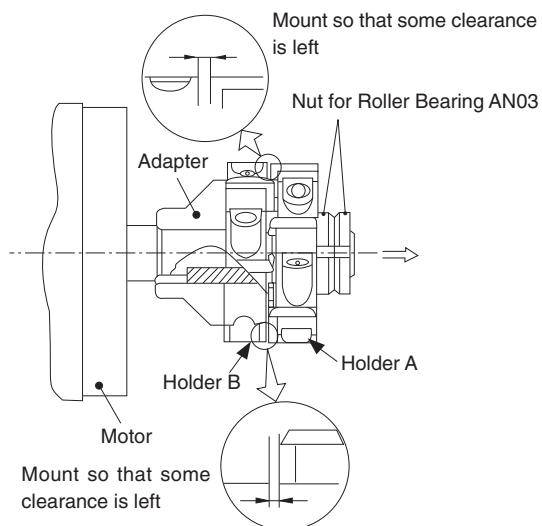

Fig.13

6 MAINTENANCE AND INSPECTION

⚠ WARNING

- Be sure to turn the switch OFF and remove the power plug from power supply during maintenance and inspection.
- Perform periodic inspection to check for loosening of the attachment screws for each part. Retighten loose screws as required.

7 CONDITION FOR USE

Burn-out chips suggest that either the feed speed is too slow or the Indexable Inserts have worn-out. Change the cutting conditions or check the conditions of the Indexable Inserts.

8 ORDERING SERVICE PARTS

For further operational and handling information or for replacement of parts and components, contact the company from whom you purchased the tool or an authorized dealer.

In ordering parts and components, give each part number, part name and quantity required.

Use only NITTO genuine parts.

9 OPTIONAL PARTS

Part No.	Description	Qty
TA9A093	Indexable Insert 12.7 Ass'y (12pcs./set)	1 set
TA9A728	Plate Ass'y for Pipe ※	1 set

※ For Pipe Out Dia. 125mm – 800mm

10 EXPLODED DIAGRAM : HB-15B

⚠ WARNING

This diagram is for your reference only. Do not attempt to service or repair the Tool. Do not take the Tool apart. Contact an authorized Nitto dealer for all service and repair of the Tool. Improper service and repair can cause accidents and service injuries. Never attempt to modify the Tool. Never attempt service or repair the Tool yourself.

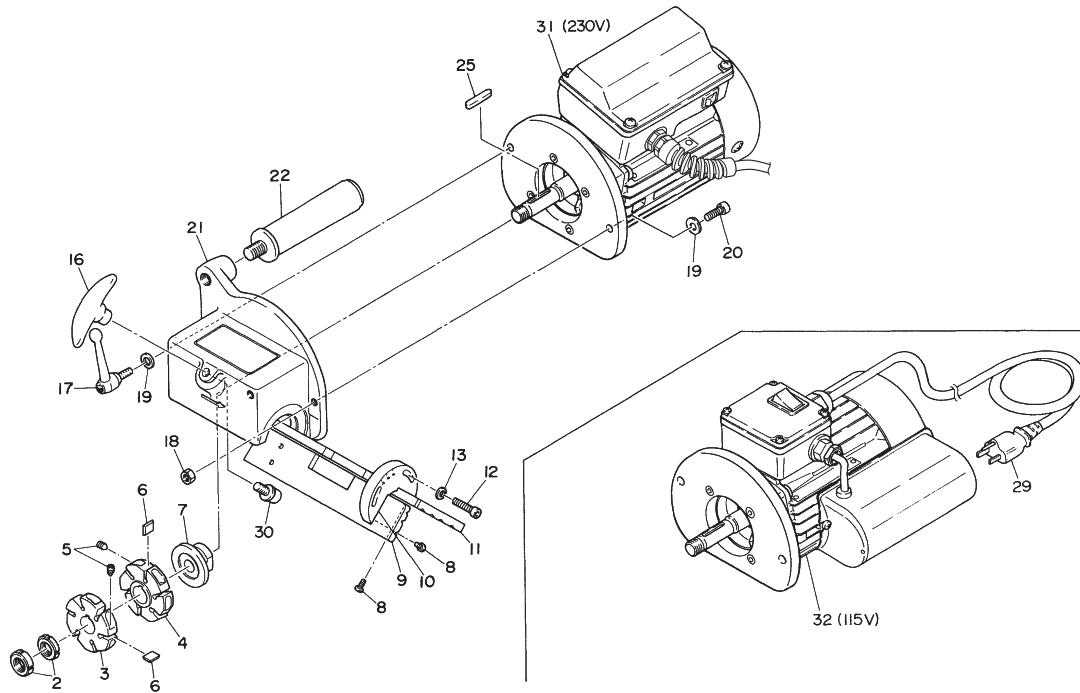

The parts numbers with () are included in the Ass'y parts written above them.

No.	Part No.	Description	Qty	Price
2	TP04157	Nut for Roller Bearing AN03	2	
3	TA9A066	Holder A Ass'y	1 set	
4	TA9A067	Holder B Ass'y	1 set	
5	(TP04689)	Hex. Socket Head set Screw 6 x 8	12	
6	TA9A093	Indexeble Insert 12.7(12pcs. / Set)	1 set	
7	TQ11091	Adapter	1	
8	TQ00208	Hex. Socket Head Screw 6 x 12	8	
9	TQ00207	Plate C	1	
10	TP16124	Plate Guide	2	
11	TQ00205	Plate A	1	
12	TP06217	Hex. Socket Head Bolt 6 x 25	4	
13	TP00092	Plain Washer M6	4	
16	TA9A074	T Handle Ass'y	1 set	
17	TP16159	Clamp Lever	1	
18	TP08584	Hex. Nut M8	1	
19	TP10978	Plain Washer M8	2	
20	TP07353	Hex. Socket Head Bolt 8 x 30	1	
21	TA99911	Body Sub Ass'y	1 set	
22	TA92089	Sub Handle Ass'y	1 set	
25	TP16151	Sunk Key 5 x 5 x 36	1	
29	TA9A757	Cabtyre Cable Ass'y	1 set	

Accessories

No.	Part No.	Description	Qty	Price
30	TQ03353	Hex. Socket Head Cap Screw 10 x 30 with Spring Washer	1	
31	TB02203	Motor Ass'y (220 V- 240 V)	1 set	
32	TB02204	Motor Ass'y (110 V- 120 V)	1 set	
	TP16613	T Wrench Key	1	
	TP01939	Hex. Socket Screw Key 4	1	
	TP04004	Hex. Socket Screw Key 5	1	
	TP00170	Hex. Socket Screw Key 6	1	
	TP04309	Spanner 24 x 27	1	
	TP16410	Hook Spanner 25 - 28	1	
	TQ00206	Plate B	1	
	TA99834	Roller Bracket Ass'y	1 set	
	TP16600	Spacer A	1	
	TP16601	Spacer B	1	
	TA9A093	Indexeble Insert 12.7(12pcs. / Set)	1 set	
	TQ13535	Instruction Manual	1	
	TQ13531	Declaration of Conformity	1	



■ Overseas Affiliates / Offices

NITTO KOHKI U.S.A., Inc.

46 Chancellor Drive, Roselle, IL 60172, U.S.A

Tel: (1)-630-924-9323 Fax: (1)-630-924-0303
<http://www.nittokohki.com/index.html>

NITTO KOHKI EUROPE Co., Ltd.

Unit 21, Empire Centre, Imperial Way,
Watford Hertfordshire, WD24 4TS, United Kingdom

Tel: (44)-01923-239668 Fax: (44)-01923-248815
<http://www.nitto.co.uk/>

NITTO KOHKI DEUTSCHLAND GmbH

Lerchenstr. 47, D-71144 Steinenbronn, Germany

Tel: (49)-7157-22436 Fax: (49)-7157-22437
<http://www.nitto-kohki.de/>

NITTO KOHKI AUSTRALIA Pty. Ltd.

77 Brandl Street, Eight Mile Plains QLD 4113,
Australia

Tel: (61)-7-3340-4600 Fax: (61)-7-3340-4640
<http://www.nitto-australia.com.au/>

NITTO KOHKI Co., Ltd. Singapore Branch

10 Ubi Crescent #01-62, Ubi Techpark Lobby D,
Singapore 408564

Tel: (65)-6227-5360 Fax: (65)-6227-0192
<http://www.nitto-kohki.co.jp/e/nksb/>

NITTO KOHKI Co., Ltd. Shanghai Representative Office

#1117 Ruijing Building, Maoming South Road,
Shanghai 200020 China

Tel: (86)-21-6415-3935 Fax: (86)-21-6472-6957
<http://www.nitto-kohki.cn/>

NITTO KOHKI Co., Ltd. Shenzhen Representative Office

#0726 International Culture Building, 3039, Shennan
Zhong Rd., Futian District, Shenzhen, 518003 China

Tel: (86)-755-8375-2185 Fax: (86)-755-8375-2187
<http://www.nitto-kohki.cn/>

NITTO KOHKI Co., Ltd. Bangkok Representative Office

38Q, House Convent Bldg, 7th Floor, Unit 7A,
Convent Rd, Silom, Bangkok, 10500 Thailand

Tel: (66)-2-632-0307 Fax: (66)-2-632-0308
http://www.nittobkk.com/eng_index.htm

EC DECLARATION OF CONFORMITY

We hereby declare that the following our product conforms with the essential health and safety requirements of EC Directives.

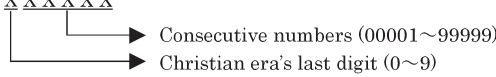
Product: ELECTRIC CHAMFERING TOOL
Model: HAND BEVELER: HB-15B
Serial No: X X X X X

Manufacturer: NITTO KOHKI Co., Ltd.
2-9-4, Nakaikegami, Ohta-ku, Tokyo, 146-8555, Japan
Authorised Compiler in the Community:
Masatoshi Ogue
President
NITTO KOHKI EUROPE Co., Ltd.
Unit21, Empire Centre, Imperial Way, Watford Hertfordshire, WD24 4TS, UK
Tel: (44)-01923-239668 Fax: (44)-01923-248815
Directive : 2006/42/EC Machinery Directive
2006/95/EC Low Voltage Directive
2004/108/EC EMC Directive

The above product has been evaluated for conformity with above directives using the following European standards.
The technical construction file (TCF) for this product is retained at the above manufacturer's location.

Machinery Directive: EN ISO12100-1:2003, EN ISO12100-2:2003,
EN ISO14121-1:2007, EN60745-1:2009, others

Name: K.Kishi

Title: GENERAL MANAGER MACHINE TOOLS DIV.

Being the responsible person appointed and employed the manufacturer.